

# eng enious

a publication for alumni and friends of the division of engineering and applied science  
*of the California Institute of Technology*

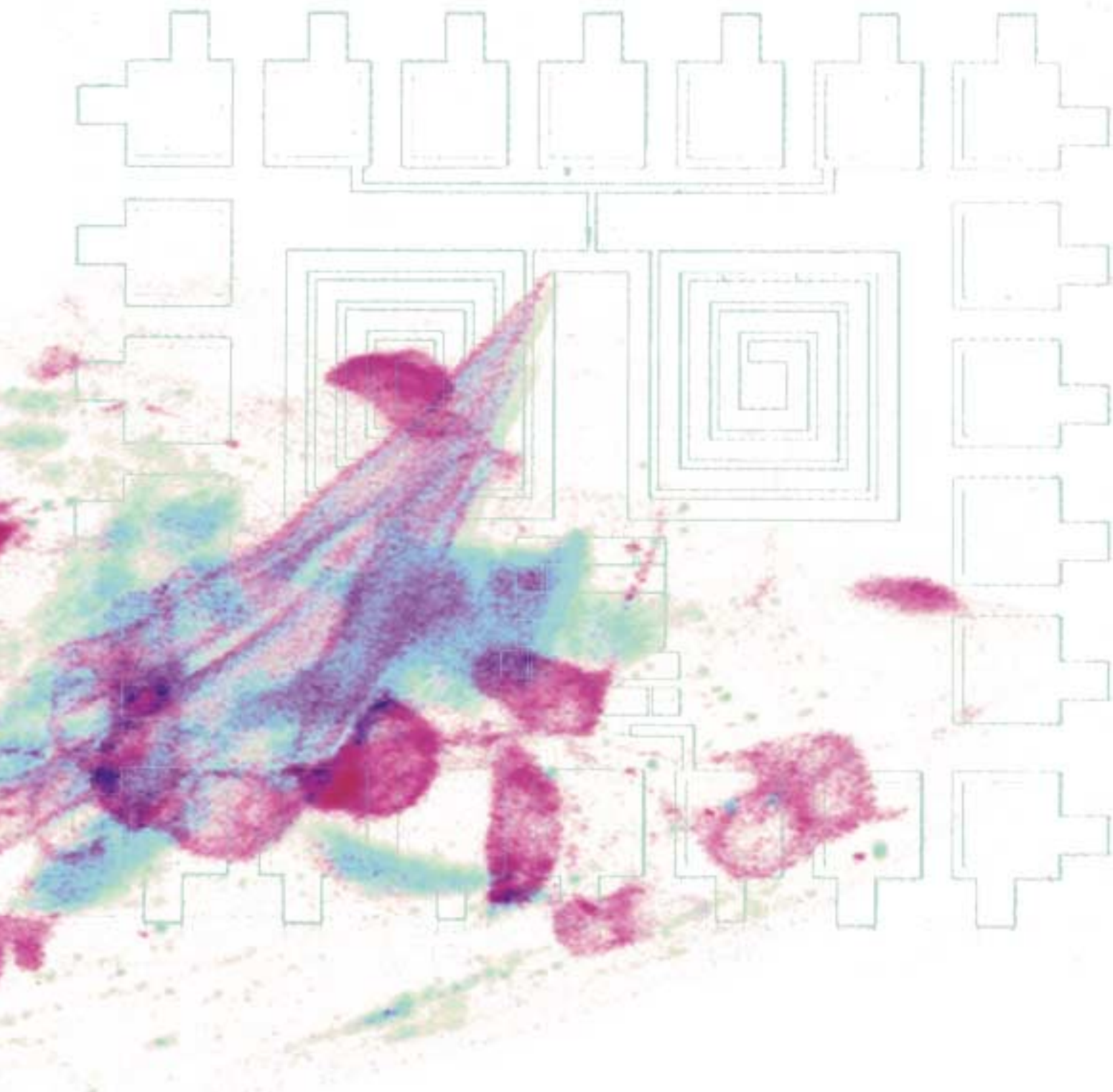

w i n t e r 2 0 0 3



The Division of Engineering and Applied Science consists of thirteen Options working in five broad areas: Mechanics and Aerospace, Information and Communications, Materials and Devices, Environment and Civil, and Biology and Medicine. For more about E&AS visit <http://www.eas.caltech.edu>.

### DIVISION CHAIR

Richard M. Murray (BS '85)

### DIVISION STEERING COMMITTEE

Jehoshua (Shuki) Bruck  
*Gordon and Betty Moore Professor of  
Computation and Neural Systems and  
Electrical Engineering*

Janet G. Hering  
*Professor of Environmental Science and  
Engineering*

Hans G. Hornung  
*C. L. "Kelly" Johnson Professor of Aeronautics*

Thomas Yizhao Hou  
*Professor of Applied and Computational  
Mathematics*

Melany L. Hunt  
*Professor of Mechanical Engineering*

Peter Schröder  
*Professor of Computer Science and Applied  
and Computational Mathematics*

Kerry J. Vahala (BS '80, MS '81, PhD '85)  
*Ted and Ginger Jenkins Professor of  
Information Science and Technology and  
Professor of Applied Physics*

P. P. Vaidyanathan  
*Professor of Electrical Engineering*

### ENGenious

#### editors

Marionne L. Epalle  
Peter Mendenhall

#### art direction/designer

Jessica Stephens

### PHOTO CONTRIBUTIONS

Linda McManus  
Peter Mendenhall  
Bob Paz  
Briana Ticehurst

### STAFF COLLABORATORS

Gillian Andrews  
*Department Assistant*

Briana Ticehurst  
*Multimedia Specialist*

### OPTIONS

**aeronautics (GALCIT)**  
[www.galcit.caltech.edu](http://www.galcit.caltech.edu)

**applied & computational mathematics**  
[www.acm.caltech.edu](http://www.acm.caltech.edu)

**applied mechanics**  
[www.eas.caltech.edu/options/appmech.html](http://www.eas.caltech.edu/options/appmech.html)

**applied physics**  
[www.aph.caltech.edu](http://www.aph.caltech.edu)

**bioengineering**  
[www.be.caltech.edu](http://www.be.caltech.edu)

**civil engineering**  
[www.eas.caltech.edu/options/civileng.html](http://www.eas.caltech.edu/options/civileng.html)

**computation & neural systems**  
[www.cns.caltech.edu](http://www.cns.caltech.edu)

**computer science**  
[www.cs.caltech.edu](http://www.cs.caltech.edu)

**control & dynamical systems**  
[www.cds.caltech.edu](http://www.cds.caltech.edu)

**electrical engineering**  
[www.ee.caltech.edu](http://www.ee.caltech.edu)

**environmental science and engineering**  
[www.es.eas.caltech.edu](http://www.es.eas.caltech.edu)

**materials science**  
[www.matsci.caltech.edu](http://www.matsci.caltech.edu)

**mechanical engineering**  
[www.me.caltech.edu](http://www.me.caltech.edu)

### CALTECH ALUMNI ASSOCIATION

*The mission of the Caltech Alumni Association is to promote the interests of Caltech as a world standard of academic excellence by strengthening the ties of goodwill and communication between the Institute, its alumni, and current students, and by maintaining programs to serve their needs. For more information on the Association and its activities, visit its website. <http://www.its.caltech.edu/~alumni>*

### SUPPORT CALTECH

<http://giving.caltech.edu>

### COMMENTS?

[engeniou@caltech.edu](mailto:engeniou@caltech.edu)

3 **note from the chair**

4 **snap shots**  
'Round About the Institute

6 **new faculty**

**Influx of Talent:** Division Grows by Nine

Marc Bockrath	Hideo Mabuchi
Michael Dickinson	Michael Roukes
Charles Elachi	Tapio Schneider
Alexei Kitaev	Chris Umans
Nadia Lapusta	

8 **progress reports**

**Understanding Material Deformation:**  
Insights into the Inner Workings of Complex Materials  
by Ersan Üstündağ

12 **Distributed Integrated Circuits:**  
Wideband Communications for the 21st Century  
by Ali Hajimiri

16 **emeritus**  
**William Bridges:** A Rare Combination of Talents  
by Amnon Yariv

---

18 **information science and technology**  
**When You Come To A Multidimensional Fork In The Road, Take It:**  
Conversations with Members of the IST Faculty Planning Committee

19	Center for Biological Circuit Design
23	Center for the Physics of Information
28	Social and Information Sciences Laboratory
31	Center for the Mathematics of Information

26 **Computing Beyond Silicon Summer School:**  
Or How I Spent My Summer in Pasadena



36 **idea flow**  
**Sensing and Responding:** Mani Chandy's Biologically Inspired Approach to Crisis Management

38 **research note**  
**Orbits of Light:** Kerry Vahala and His Miniature Lasing Spheres

40 **alumni profiles**  
**Ivett Leyva:** An Experimentalist with International Flair  
Aeronautics, PhD '99

41 **Eric Garen:** Education at the Fore  
Electrical Engineering, BS '68

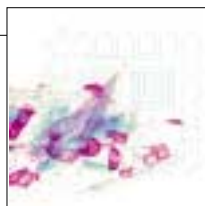

**Cover Image:** The montage on the cover symbolizes the melding of biology and circuits—one essential theme of ISTI: the Information Science and Technology Institute. ISTI is dedicated to systematically exploring information science and technology on several fronts, including the theoretical underpinnings, biological circuit design, the physics of information, and societal structures such as financial markets and social organizations. Starting on page 18 are four conversations with the Caltech faculty charged with laying the groundwork for this new enterprise.

Cover components: The organic shape is *C. elegans*, a nematode from Professor Paul Sternberg's lab. Professor Jehoshua Bruck, in collaboration with Sternberg, studies the nematode as a proving ground for computational models. The circuit, a low-noise device from Professor Ali Hajimiri's lab, is a precursor to Hajimiri's current work in distributed integrated circuits (see page 12).



## n o t e f r o m t h e c h a i r

*This is our third issue of **engeniouS** and I am coming up on my third anniversary as Division Chair for the Division of Engineering and Applied Science. One of the accomplishments that I'm very proud of is the establishment of a strategic plan for the Division, developed with the help of representatives from each of the options and major centers in the Division. This plan is guiding our educational programs, our faculty hiring, and our fundraising activities, and is being further developed by faculty planning committees in each of the major thrust areas. If you'd like to have a look, it's available online at [http://www.eas.caltech.edu/strategic\\_plan](http://www.eas.caltech.edu/strategic_plan); we would welcome your comments and feedback.*

*Our feature piece reports on the formation of Caltech's Information Science and Technology Institute (ISTI), one of the major elements of our strategic plan. The article fills almost one-third of this issue, indicating how important and far-reaching the research and teaching efforts of this new venture will ultimately be. Campus-wide, one-fifth of the faculty and one-third of all students will be involved in this multi-layered, multidisciplinary exploration of the analysis and design of complex natural and synthetic information systems. With its center of gravity in E&AS, ISTI will give us tremendous reach in bringing the best and brightest to Caltech, creating an approach that is likely to be emulated elsewhere, and changing the way the world thinks about and harnesses information. ISTI is a rare opportunity to pull the future a little closer.*

*As we look around the rest of this issue, you will notice an addition to one of the regular features. Our Alumni section profiles two alums, a younger one (graduated within the last 5 years) and a more established one. We hope you'll enjoy (and reminisce) reading about the post-Tech adventures of Ivett Leyva (PhD '99) and Eric Garen (BS '68).*

*Sincerely,*

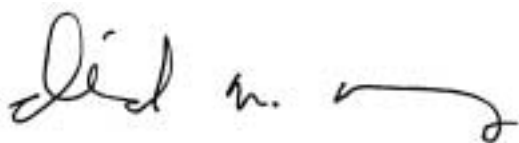

**richard m. murray**  
*Chair, Division of Engineering and Applied Science*



Image at left: Domain patterns in the ferroelectric material  $\text{PbTiO}_3$  obtained by using polarized light microscopy. Such microscopic patterns form spontaneously in ferroelectric materials giving rise to unique electro-mechanical properties which are useful for applications in micromachines. Nine faculty members from E&AS are investigating how such patterns can be engineered to produce desired properties well beyond those currently available, and at the limits of what is theoretically possible (see <http://www.femuri.caltech.edu>). This photograph was taken by graduate student Rongjing Zhang in the laboratory of Professor G. Ravichandran. The area imaged is about 2.5 mm x 1.2 mm.

## 'Round About the Institute



Erik Antonsson

## Go, Erik, Go: JPL's Chief Technologist, Erik Antonsson

**Erik Antonsson**, professor of and former executive officer for mechanical engineering, has a new calling: chief technologist for the Jet Propulsion Laboratory (JPL). A national search led by Richard Murray, professor of mechanical engineering and chair of the Division of Engineering and Applied Science, followed a long and winding road to Erik's door. They knocked, and he answered. Charles Elachi, director of JPL, said, "Dr. Murray and his committee interviewed a number of nationally recognized technology leaders and determined that Dr. Antonsson's expertise and experience are an outstanding match for the position." Erik began his two-year leave of absence from Caltech last September (though he still comes to campus one day a week to continue his research).

Probably best known to the public as the creator and driving force behind the course ME 72 and its wildly serious engineering-design contest, Erik will no doubt have new seriously wild adventures at JPL that he may incorporate into future ME courses.

Find out more about Professor Antonsson at [http://www.design.caltech.edu/erik/antonsson\\_bio.html](http://www.design.caltech.edu/erik/antonsson_bio.html)

## Two VPs and a Dean: Margo Marshak, Gary Dicovitsky, and Erica O'Neal Join Caltech

**Three new administrative appointments** are bringing a wealth of talent to Caltech's door. Dr. Margo Marshak is Caltech's new vice president for student affairs. "I'm obviously thrilled to have the opportunity to come to such a great institution," says Marshak. "I'm enormously impressed with the quality of the students, faculty, and administration." Fresh from her role as vice president and dean of students at the University of Chicago, Marshak will be the senior Caltech executive responsible for envisioning, leading, advocating for, and managing student welfare and interests.

Gary Dicovitsky is the new vice president for development and alumni relations. Most recently, he served as vice president for development at Pomona College. "Caltech's superior reputation as a research and teaching institution with such depth and capacity in interdisciplinary projects and programs was fundamental to my interest," remarked Dicovitsky. "I am honored to be offered the privilege to help build on the institution's past successes and to interact with such extraordinary faculty, staff, and alumni."

Dr. Erica O'Neal is Caltech's new associate dean and director of the office for multicultural education and student affairs. She arrived at Caltech from Stanford, where she served as associate director of development in the School of Humanities and Sciences and previously as an assistant dean in the School of Engineering. "I am enthusiastic about joining the Caltech family and making new contributions that serve to increase diversity and build community among the student body," says O'Neal. A *cum laude* graduate of Harvard, O'Neal holds an MS and a PhD in higher education from the University of Pennsylvania.



From left to right: Margo Marshak, Gary Dicovitsky, and Erica O'Neal.



Simon Wilkie

## Simon Wilkie Goes to Washington:

New Chief Economist for the FCC

**Simon Wilkie**, a senior research associate in economics at Caltech, has assumed the position of chief economist for the Federal Communications Commission (FCC), the agency responsible for regulating the likes of, well, just about everything in our media-mediated world. The FCC, established in 1934, is responsible for regulating interstate and international communications by radio, television, wire, satellite, and cable. As chief economist, it is Wilkie's responsibility to provide independent, nonpartisan advice—from an economic perspective—to the commissioners on various regulatory issues.

"We sort through what is oftentimes conflicting advice given to the FCC, then provide guidance to the commissioners and the chairman."

He notes that Congress, for example, will mandate that the FCC should do certain things, like develop regulations for telephone network access by new market entrants, or develop a fair system for auctioning off high-speed bandwidth. But, they don't spell out the specifics of how to do it. "Our job is to come up with the right formula that works, one that is fair to all concerned, and in the best interests of the public."

## Stainless Steel, Travertine, and the Biological Sciences: The Broad Center

**Caltech has a new building**, and it's a looker. (See the inside back cover for a glimpse.) The Broad Center for the Biological Sciences was dedicated in September 2002, and will use its 120,000 square feet to house laboratories and offices for 13 research teams focusing on magnetic imaging, computational molecular biology, and investigation of the biological nature of consciousness, emotion, and perception. Principal funding for the structure came from Caltech trustee Eli Broad and his wife, Edythe.

Speakers at the opening included David Baltimore, president of Caltech; Benjamin Rosen, chairman of the Caltech Board of Trustees; Allen Rudolph, principal with construction company Rudolph and Sletten; Elliot Meyerowitz, chair of the Division of Biology and professor of biology; and Eli Broad. "The Broad Center adds a distinguished architectural achievement to Caltech's already beautiful campus," said Baltimore. "It is a testament to the generosity of many friends of Caltech, led by Eli and Edye Broad, and to the genius of James Freed, its design architect. Most importantly, it's a highly functional building, providing a framework for advances in the biological sciences in the 21st century."



There's always room for more at the Sturtevant Spa.

## In Hot, Bubbly Water: New Comfort Zone Added to Braun Athletic Center

**Bradford Sturtevant's family and friends** have created for the Caltech community a place of respite after long days of using brains and brawn. The Sturtevant Memorial Spa was dedicated on May 2, 2002, commemorating the late Bradford Sturtevant, Liepmann Professor of Aeronautics. A seemingly tireless swimmer and promoter of swimming, Sturtevant was a strong advocate for athletics at Caltech, and served for many years on the faculty athletics committee. He played a key role in the planning and construction of the Braun Athletic Center, as well as the planning and construction of the Sherman Fairchild Library of Engineering and Applied Science.

Learn more about our athletics facilities at <http://www.athletics.caltech.edu>

## Influx of Talent: Division Grows by Nine

Six new professors have joined the Division and Caltech over the past several months, bringing fresh insights and new research directions our way.



Also new to the Division are three faculty members already part of the Caltech community: (pictured from left to right) Charles Elachi, Director of the Jet Propulsion Laboratory, joins Electrical Engineering; Hideo Mabuchi is now a member of both the Physics faculty and the Control and Dynamical Systems Option; and Michael Roukes, also a member of the Physics faculty, joins both the Applied Physics and Bioengineering Options.

### Marc Bockrath: Assistant Professor of Applied Physics

Professor Bockrath's interests are in nanofabrication, and the electronics and mechanics of systems that have critical dimensions on the nanometer scale, which represents the ultimate limit to miniaturization. These systems include materials such as carbon nanotubes and individual molecules. Currently, he is interested both in investigating the new and interesting transport phenomena that arise in nanostructured materials, and in investigating the properties of nanostructures that have mechanical degrees of freedom. Potential applications include nanoscale switches, logic gates, and sensors.

Bockrath received a BS degree in Physics from the Massachusetts Institute of Technology in 1993, and a PhD in Physics from UC Berkeley in 1999. Most recently he was a postdoctoral fellow at Harvard University.



### Michael Dickinson: Professor of Bioengineering

Professor Dickinson's primary research interests concern the physiology and mechanics of flight behavior in insects. Specifically, he has focused on the flight-control system of flies—arguably the most aerodynamically sophisticated of all flying animals. His research strategy is to tackle flight behavior using approaches from such disparate disciplines as neurobiology, structural engineering, and aerodynamics. Thus, Professor Dickinson's lab attempts to study flight-control behavior at several levels of analysis simultaneously, from the physiological properties of individual neurons and circuits to the skeletal mechanics of wing motion and the production of aerodynamic forces. This multi-level approach is challenging and yet rewarding, as novel insight is often gained by addressing a problem simultaneously from several perspectives.

Dickinson received his ScB degree from Brown University in 1984 and a PhD in Zoology from the University of Washington in 1989. He comes to Caltech from UC Berkeley, where he was the Williams Professor of Integrative Biology.



### Alexei Kitaev: Professor of Theoretical Physics and Computer Science

Professor Kitaev's research area is quantum computation, which includes quantum algorithms, error correction, and quantum complexity classes. Professor Kitaev has devised a phase-estimation algorithm and topological quantum codes, as well as an efficient classical algorithm for the approximation of unitary operators by products of generators. He has also studied complexity classes BQNP and QIP. His other important idea is error correction at the physical



level, in particular fault-tolerant quantum computation by anyons. He is currently working on physical models that would make this scheme feasible.

Kitaev received an MS degree from the Moscow Institute of Physics and Technology in 1986, and a PhD from the L.D. Landau Institute for Theoretical Physics in 1989. He worked at the L.D. Landau Institute until 1998, then spent a year at Caltech as a visiting researcher and lecturer, two years at Microsoft as a researcher, and came back to Caltech as a senior research associate in fall 2001.

Professor Kitaev has a joint appointment in the Division of Engineering and Applied Science and the Division of Physics, Mathematics, and Astronomy.

## Nadia Lapusta: Assistant Professor of Mechanical Engineering

**Professor Lapusta's** research interests are in continuum mechanics, computational modeling, fracture and frictional processes, and the mechanics and physics of earthquakes. Her work is directed towards understanding fracture and frictional phenomena on all scales, from frictional failure in earthquakes and dynamic cracks in solid structural components to tribological processes on micron-sized asperities and complex atomic and molecular interactions at crack tips. A significant effort is devoted to developing efficient computational techniques applicable to such nonlinear, dynamic, and multiscale problems. Her current studies include nucleation and dynamics of frictional instabilities, models of earthquake sequences, dynamic fracture on bimaterial interfaces, and shear heating effects during rapid slips.

Lapusta received her Diploma in Mechanics and Applied Mathematics from Kiev State University (Ukraine) in 1994, and both her SM (1996) and PhD (2001) degrees in Engineering Sciences from Harvard University.



## Tapio Schneider: Assistant Professor of Environmental Science and Engineering

**Professor Schneider's** research interests are in the dynamics of the global circulation of the atmosphere and in large-scale atmospheric turbulence and turbulent transport. His current research focuses on developing theories concerning the turbulent fluxes of heat, mass, and water vapor that contribute to maintaining such basic climatic features as the pole-to-equator surface-temperature gradient, the thermal stratification of the atmosphere, and the distribution of atmospheric water vapor.

Schneider received his PhD from Princeton University in 2001, and did his undergraduate work at Freiburg University (Vordiplom, 1993).

Professor Schneider has a joint appointment in the Division of Engineering and Applied Science and the Division of Geological and Planetary Sciences.

## Chris Umans: Assistant Professor of Computer Science

**Professor Umans's** research area is theoretical computer science, in particular complexity theory. He has studied the computational complexity of fundamental optimization problems from application areas such as circuit design and learning theory. His recent work centers on basic questions regarding the power of randomness in computation. Other research interests include explicit combinatorial constructions, hardness of approximation, coding theory, and algorithms for problems from graph theory and algebra.

Umans received a BA degree in Computer Science and Mathematics from Williams College in 1996, and a PhD in Computer Science from UC Berkeley in 2000. Before joining Caltech, he was a postdoctoral scholar in the Theory Group at Microsoft Research.

## Understanding Material Deformation: Insights into the Inner Workings of Complex Materials

by Ersan Üstündag

In most engineering calculations, the mechanical performance of structures or components is estimated under the assumption that the material is homogeneous or can be represented by a continuum. Although this assumption is often sufficient, it prevents a true understanding of deformation mechanisms, as most structural materials are actually composites (comprised of multiple phases) and/or polycrystals (composed of many grains). It turns out that the interactions between phases and grains largely determine the overall behavior of the material. These interactions occur over multiple length scales, from nanometers to centimeters. Any experimental technique that intends to fully characterize material deformation must be sensitive to such a scale range. The technique must also be non-intrusive, as it should not cause damage while interrogating the material. Another important requirement is that the technique should allow *in-situ* studies, that is, monitoring of material deformation under a variety of conditions, such as applied load, temperature, or atmosphere.

Diffraction is a powerful technique for material characterization, and easily satisfies these requirements. Especially attractive methods are x-ray and neutron diffrac-

tion, as they provide *in-situ* information about internal strains (and indirectly, stresses), crystallography (to help identify different phases), and texture (or preferred grain orientation). Diffraction techniques use a material's crystalline lattice as an "internal gauge," and are therefore sensitive to changes occurring on the atomic scale. In addition, when a large sampling volume is chosen, contributions from many regions are included in the overall "signature" of the material, leading to an effective averaging or bulk characterization. X-ray and neutron diffraction can be used independently or in a complementary manner, as the former can probe sub-micrometer regions while the latter is more suitable for *in-situ* bulk studies on the scale of millimeters to centimeters.

In our research, we employ both x-ray and neutron diffraction for a complete, multiscale characterization of material deformation. Our aim is to develop accurate constitutive laws describing the behavior of a composite or a polycrystal. Accurate description of constitutive behavior is crucial for successful modeling of material behavior, including prediction of expected lifetime. We anticipate that our



Ersan Üstündag

models will be valuable to engineers designing and constructing complicated structures or devices as varied as jet turbine engines, cars, buildings, satellites, and electronic chips.

This report details one important aspect of our research, namely the use of neutron diffraction in deformation studies. It also describes our recent efforts to design and construct a dedicated engineering neutron spectrometer called SMARTS. Much more than a catchy acronym (standing for Spectrometer for MAterials

Research at Temperature and Stress), SMARTS is currently unique in the world. It is the first instrument specifically designed for engineering stress/strain studies at a spallation neutron source. Located at the Los Alamos Neutron Science Center (LANSCE) in New Mexico, it was commissioned in 2001. It is funded by the Department of Energy (Office of Basic Energy Sciences), and was built by a team led by the author.

SMARTS is expanding the use of neutron diffraction to a wider range of engineering problems than was previously possible. With its extensive array of *in-situ* capabilities for sample environments, it enables measurements on small (1 mm<sup>3</sup>) or large (1 m<sup>3</sup>) samples. Ease of access to the sample bay is one significant new feature. Components with dimensions up to 1 meter and mass up to 1,500 kilograms can be positioned precisely in the path of the neutron beam. Permanently mounted alignment theodolites provide a simple and efficient way to position samples or equipment to within 0.01 mm. Achieving this level of precision is critical for stress-strain measurements; misalignments of more than 0.1 mm can result in significant pseudo-strain artifacts.

A furnace and load-frame suite allows research on materials under extreme loads (60,000 pounds or 250 kN) and at extreme temperatures (1,500°C or 2,700°F). *In-situ* uniaxial loading on samples 1 cm in diameter at stresses over 3 GPa

under vacuum or in a controlled atmosphere is now routine. This represents a significant increase over previous standards. Some of the exciting capabilities provided by SMARTS include measurements of spatially resolved strain fields; phase deformation, and load transfer in composites; the evolution of stress during high-temperature fabrication; and the development of strain during reactions or phase transformations.

The layout of SMARTS is shown in Figure 1. At LANSCE, neutrons are produced by spallation, which involves accelerating protons to very high energies toward a tungsten target, then collecting the polychromatic neutrons that form. These neutrons pass through a water moderator, which reduces their energies to a range suitable for diffraction. After passing through the T<sub>0</sub> chopper, a device which further removes fast neutrons and the gamma flash (to minimize background), the thermal neutrons reach the guide. The guide is coated with <sup>58</sup>Ni, and, via the process of near-total reflection, keeps most of the neutrons in the beam path. The guide terminates at the inner surface of the cave wall. Two aperture sets (located between the exit of the guide and the sample) permit the beam cross-section to be defined continuously in shape and area between 1 and 100 mm<sup>2</sup>.

When the neutron beam penetrates a sample, some of the neutrons interact with atoms in the

material and scatter in all directions. Some of these reach one of the two detector banks centered on the horizontal plane at 90° to the incident beam. Each detector consists of three panels with a total of 192 <sup>3</sup>He gas-filled aluminum tubes. Interactions between the neutrons and <sup>3</sup>He in the detector tubes produce <sup>4</sup>He plus gamma radiation and ionize the gas, creating a cascade of electrons with associated charges. These charges are digitized and converted electronically to patterns of intensity versus scattering angle. Data from the tubes are combined to provide time-of-flight neutron-diffraction patterns. Analysis of the diffraction patterns is carried out with a least-squares fitting routine called the Rietveld method. Data acquisition is based on virtual memory extension technology and uses web-based visualization and control software.

Experiments can be controlled remotely from the user's laboratory (anywhere in the world), and real-time data analysis can be accomplished with a unique software package called *Expert System*. This software represents a radical new approach to experiment planning and execution in the neutron-diffraction field. For the first time, the experimenter has a chance to optimize an experiment according to his/her needs and predict results even before starting. Moreover, during the experiment, data are

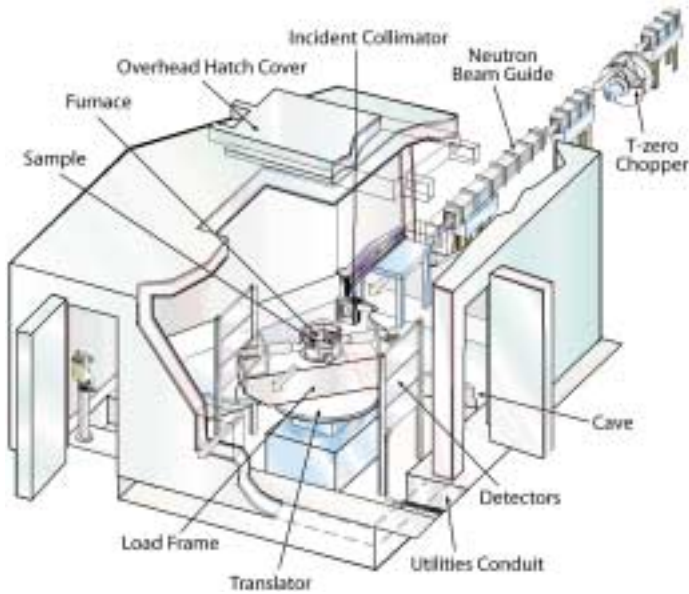

Figure 1. Neutrons from the moderator pass through a series of collimating apertures before entering the neutron guide. A  $T_0$  chopper removes fast neutrons and gamma flash that would otherwise contribute unwanted background. Slow thermal neutrons continue down the guide to the entrance of the SMARTS cave (about 5 x 6 m in size). On exiting the guide, neutrons pass to the center of the cave where some are scattered by the sample to the detectors. Samples or ancillary systems are placed directly on the translator, which can accommodate up to 1,500 kg, move in three orthogonal directions, and rotate about a vertical axis. Theodolites provide precise optical triangulation and alignment capability for equipment or samples. Here, the load-frame-furnace suite is shown on top of the translator. In some experiments where a three-dimensional sampling volume is desired, radial collimators are inserted between the detectors and the sample. When used with the incident collimation, selection of an appropriate radial collimator defines a sampling volume for spatially resolved measurements.

analyzed in real time, allowing a quick assessment of the results. Figure 2 describes the interactions between the user and the various components of Expert System.

First, the user is asked to input detailed material data and the strain error desired. The software then simulates the expected diffraction pattern. This calculation incorporates realistic models of the instrument optics so that the simulated pattern is truly representative of the sample. In addition, based on the experimental parameters (e.g., tension vs. compression) and specimen characteristics (e.g., monolith vs. composite), Expert System will soon be able to perform several mechanics calculations that will simulate the stress-strain behavior of the material. This is necessary to determine the optimum data-collection points so that all critical events during a material's deformation (for instance, its yield point) can be captured. Another planned upgrade involves optimization of experimental conditions using inverse problem analysis. This will yield the mathematically most opti-

mum set of data points required to obtain a desired outcome in the shortest possible time. The latter issue is important since beam time is very expensive. For this reason, the current version of Expert System includes real-time data analysis to determine the exact time when enough data have been collected to satisfy the user's specified initial error value.

Expert System was mostly programmed by a group of undergraduate students led by Richard Karnesky (BS '02, past president of Ricketts House) who is now pursuing a PhD degree at Northwestern University. Other contributors include Justin Fox (currently a senior in E&AS) and Dr. Bjorn Clausen (of Los Alamos). The software was written in Java, so it can be used on different computing platforms and run over the Internet. We expect it to be adopted by various national facilities, both for neutron and x-ray diffrac-

tion. When this occurs, robust data comparison between these facilities will be achieved for the first time. This is also expected to lead to standardization of engineering

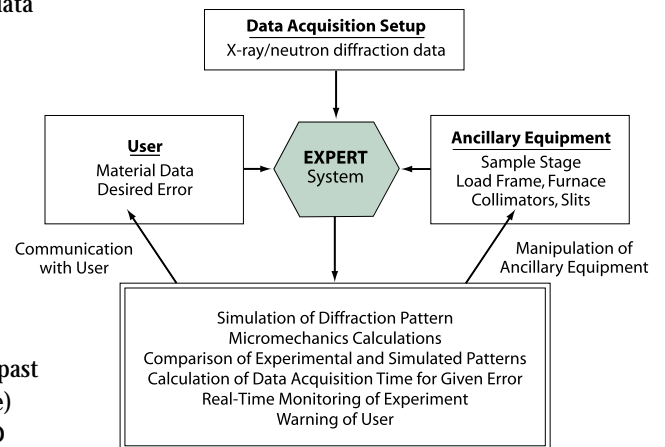

Figure 2. Schematic illustration of the working principle of the SMARTS Expert System software.

stress/strain measurements using diffraction. The outcome will likely be a rapid growth of the field and its application to a multitude of materials science and engineering

problems in both academe and industry.

During the commissioning phase, we used SMARTS for a variety of projects. In a study funded by NASA, we investigated high-temperature deformation mechanisms in structural ceramics and ceramic-matrix composites. Some of these materials are already in use in new jet turbine engines, but before they can be employed further, it is necessary to understand their “creep” behavior. Creep refers to permanent (i.e., inelastic) deformation at high temperatures. This understanding will allow us to construct advanced models that predict the lifetime of these materials under demanding conditions (temperatures above 1,200°C, highly corrosive atmospheres, and so on). Since SMARTS is able to provide temperatures similar to those found in a jet turbine, we collected *in-situ* crystallographic data for the first time for one of the most important structural ceramics,  $\text{Si}_3\text{N}_4$ . The diffraction data (including lattice plane specific strains) were used in a self-consistent model to calculate the elastic stiffness tensor of this material at this temperature—a calculation previously unattainable. In late 2002, additional  $\text{Si}_3\text{N}_4$  tests were conducted in the creep regime. The results suggest that grain rotation and boundary sliding are active creep mechanisms. This is the first time that they have been observed *in situ*. The data are now being used to develop a new mechanics model.



We have also used SMARTS to study bulk metallic glass (BMG) matrix composites developed at Caltech by Professor Bill Johnson's group. These composites retain the high strength of BMG but improve it further by providing ductility and damage tolerance. Our aim was to understand deformation mechanisms in these composites and to identify the best reinforcement material and its morphology. Some BMG matrix composites require applied stresses over 2 GPa to fully observe their deformation. However, since they include heavy elements (such as zirconium and tungsten) that absorb x-rays, neutron diffraction (and SMARTS specifically) is the only technique available to study *in-situ* deformation of the reinforcements under high applied stress.

Due to its amorphous nature, the BMG matrix cannot be interrogated directly with diffraction to obtain lattice-strain data. However, we were able to use diffraction data to develop new mechanics models (finite-element or self-consistent) that allowed deduction of the behavior of the BMG matrix. We showed that in all composites, the metallic reinforcements yield first and then start transferring load to the BMG matrix. The matrix later deforms by initiating multiple shear bands that make it “plastic,” enhancing the overall ductility of the composite. The full micromechanical details of these events are still not fully understood however.

To achieve greater understanding, we have started working on model specimens suitable for high-energy x-ray diffraction studies. By combining the neutron-diffraction data we have obtained so far with the spatially resolved x-ray diffraction data, we intend to elucidate the complete, multiscale deformation mechanisms in BMG matrix composites.



In short, the SMARTS system we have built together with the Expert System software allow

unprecedented experimental capabilities that are revolutionizing our ability to characterize materials *in situ* under a variety of environmental conditions close to what materials will actually encounter. This is expected to lead to a better understanding of how various materials fail, and how we can improve the design of practical systems, such as aircraft, cars, engines, buildings, and even microdevices, to avoid such failure.   

---

*Ersan Üstündag is Assistant Professor of Materials Science.*

There is more on Professor Üstündag at [http://www.matsci.caltech.edu/people/faculty/ustundag\\_e.html](http://www.matsci.caltech.edu/people/faculty/ustundag_e.html) and more about his project at <http://smarts.caltech.edu>

# Distributed Integrated Circuits: Wideband Communications for the 21st Century

by Ali Hajimiri

G

lobal communications have rendered our world a smaller, yet more interesting place, making it possible to exchange visions, ideas, goals, dreams—and PoKéMoN cards—across our small planet. Modern communications systems, such as the internet and portable wireless systems, have added new dimensions to an already complex world. They make us aware of our similarities and differences and give us an opportunity to communicate with people we have never met from places we have never been. The fusion of education with communication is already bringing about new levels of awareness, accompanied by creative upheavals in all aspects of modern life.

However, the ever-increasing demand for more connectivity inevitably increases the complexity of such systems. Integrated systems and circuits continue to play a central role in the evolution of component design. Silicon-based integrated-circuit technologies (particularly complementary metal oxide semiconductor, or CMOS) are the only technologies to date capable of providing a very large number (over a



Ali Hajimiri

million) of *reliable* active (e.g., transistors) and passive (e.g., interconnect) devices. Further, they are relatively inexpensive to incorporate into mass-market products.

The realization of revolutionary ideas in communications depends heavily on the performance of the integrated electronic circuits used to implement them. Let's consider some well-established theoretical background for a moment. The maximum number of bits (1s and 0s) that can be trans-

mitted per second (i.e., *bit rate*) determines the speed of a digital communications system. C.E. Shannon, the founder of modern information theory, proved that the maximum achievable bit rate of a digital communications system increases linearly with the available range of frequencies (i.e., *channel bandwidth*) and logarithmically with the signal-to-noise ratio. Thus, three critical parameters, namely, *bandwidth*, *signal power*, and *noise*, are the most important parameters in determining the performance of any given communications system.

One of the more common methods of increasing the bandwidth, and hence the bit rate, of any given system is to migrate to higher operating frequencies. The maximum speed of operation in electrical systems is determined by the performance of both active and passive devices. While in modern integrated-circuit technologies the single-transistor maximum frequency of operation can be quite high, actual circuits rarely operate anywhere near these frequencies.<sup>1</sup> This provides further motivation to pursue alternative approaches to allevi-

<sup>1</sup> A transistor in a given process technology is usually characterized by its unity-gain frequency shown as  $f_T$ . This is the frequency at which the current gain (the ratio of the output current to input current) of a transistor drops to unity. While the unity-gain frequency of a transistor provides an approximate measure to compare transistors in different technologies, the circuits built using these transistors scarcely operate close to the  $f_T$  and usually operate at frequencies 4 to 100 times smaller depending on the complexity of their function. There are two main reasons for this behavior. First, many systems rely on closed-loop operation based on negative feedback to perform a given function independent of the parameter variations. An open-loop gain much higher than one is thus required for the negative feedback to be effective. This higher gain can be only achieved by operating the transistors at a lower frequency than the  $f_T$  to provide the desired gain. Second, integrated passive devices necessary in most of the high-speed analog circuits have their own frequency limitations due to parasitic components that can become design bottlenecks. The combination of these two effects significantly lowers the maximum frequency of reliable operation in most conventional circuit building blocks

ate bandwidth limitations, particularly in silicon-based systems which, despite their reliability, suffer from low transistor speed, poor passive performance, and high noise compared with other technologies.

The complex and strong interrelations between constraints in modern communications systems have forced us to reinvestigate our approach to system design. “Divide and conquer” has been the principle used to solve many scientific and engineering problems. Over many years, we have devised systematic ways to divide a design objective into a collection of smaller projects and tasks defined at multiple levels of abstraction artificially created to render the problem more tractable. While this divide-and-conquer process has been rather successful in streamlining innovation, it is a double-edged sword, as some of the most interesting possibilities fall in the boundary between different disciplines and thus hide from the narrow field of view available at each level. Thus, approaching the problem across multiple levels of abstraction seems to be the most promising way to find solutions not easily seen when one confines the search space to one level.

*Distributed* circuit and system design is a multi-level approach allowing more integral co-design of the building blocks at the circuit and device levels. This approach can be used to greatly alleviate the frequency, noise, and energy efficiency limitations of conventional circuits. Unlike conventional circuits, which often consist of a sin-

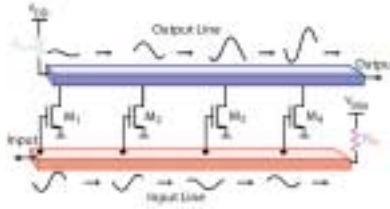

Figure 1. A distributed amplifier consisting of two transmission lines and multiple transistors providing gain through multiple signal paths that amplify the forward traveling wave. Each transistor adds power in phase to the signal at each tap point on the output line. Each pathway provides some gain and therefore the whole amplifier is capable of providing a higher gain-bandwidth product than a conventional amplifier.

gle signal path, distributed integrated systems and circuits rely on multiple parallel paths operating in harmony to achieve an objective. However, this multiple signal-path feature often results in strong electromagnetic couplings between circuit components, which makes it necessary to perform the analysis and the design of distributed circuits across multiple levels, a task not crucial when using the “divide and conquer” approach.

This concept can be best seen through the distributed amplifier (originally suggested by Percival and first implemented by Ginzton) sketched in Figure 1. This amplifier consists of two transmission lines on the input and the output, and multiple transistors providing gain through multiple signal paths. The forward (to the right in the figure) wave on the input line is amplified by each transistor. The incident wave on the output line travels forward in synchronization with the

traveling wave on the input line. Each transistor adds power in phase to the signal at each tap point on the output line. The forward traveling wave on the gate line and the backward (traveling to the left) wave on the drain line are absorbed by terminations matched to the loaded characteristic impedance of the input line,  $R_{in}$ , and output line,  $R_{out}$ , respectively, to avoid reflections.

In a distributed amplifier, one tries to avoid a “weakest-link” situation by providing multiple, equally strong (or equally weak) parallel paths for the signal. In the absence of passive loss, additional gain can be achieved without a significant reduction in the bandwidth by addition of extra transistor segments. This is the direct result of multiple signal paths in the circuit. The extended bandwidth of the distributed amplifier comes at the price of a larger time delay between its input and output, as there is a trade-off between the bandwidth and delay in an amplifier. Alternatively, one can think of this approach as a method of absorbing the parasitic capacitances of the transistors into the transmission lines and making them a part of the passive network.

**A**

t Caltech, one of our most exciting breakthroughs has been in the area of silicon-based distributed circuits for communication systems; we have achieved unprecedented performance for communication blocks and systems.

In particular, we have used the concept of distributed systems to demonstrate an extremely high-speed voltage-controlled oscillator using a low-performance CMOS technology with small cut-off frequencies for the active and passive components (see Figure 2). This oscillator uses the delay introduced by the distributed amplifier to sustain electrical oscillation by continuous amplification of the signal around a loop. The oscillation frequency is determined by the round-trip time delay, i.e., the time it takes the wave to travel through the transmission lines and get amplified by the transistors.

Tunability is an essential feature for such distributed voltage-controlled oscillators (DVCOs), and thus it is necessary to devise a method to control the oscillation frequency. The oscillation frequency is inversely proportional to the total delay and hence the total length of the transmission lines. This property leads to a frequency tuning approach based on changing the effective length of the transmission lines. Frequency control can be achieved by introducing shortcuts in the signal path. This concept can be seen using the racetrack analogy of Figure 2a. Here the signals traveling on the input and output lines are analogous to two runners on two tracks running side-by-side to be able to pass a torch at all times. The time it takes them to complete a lap (oscillation period) can be changed by introducing symmetrical shortcuts for both of them and controlling what percentage of the time they go through each one.

This concept has been successfully demonstrated in the distributed voltage-controlled oscillator of Figure 2b where alternative signal paths have been introduced to change the electrical length seen by the traveling wave.

Another component we have devised is the distributed active transformer (DAT) power amplifier. The design of a fully integrated silicon-based power amplifier with high output power, efficiency, and gain has been one of the unsolved major challenges in today's pursuit of a single-chip integrated communication systems. Although several advances

have been made in this direction, a watt-level, truly fully integrated CMOS power amplifier has not been demonstrated using the traditional power-amplifier design techniques.

**T**wo main obstacles in the design of a fully integrated power amplifier are the low breakdown voltages of

transistors and the high losses of passive components. The low breakdown voltage limits the voltage swing at the output node, which in turn lowers the produced output power. The high passive loss reduces the amplifier's power efficiency by dissipating the generated power in the signal path. These problems are exacerbated in most commonly used CMOS process technologies, as the MOS transistor's minimum feature size is continuously scaled down for faster operation, resulting in lower substrate resistivity and smaller breakdown voltages.

Our DAT power amplifier uses the distributed approach to perform impedance transformation and power combining simultaneously to achieve a large output power while maintaining acceptable power efficiency. It overcomes the low breakdown voltage of short-channel MOS transistors and alleviates the substrate loss problems by providing the power gain through multiple similar stages and signal paths.

Figure 3a shows the essential features of the DAT, which consists of multiple distributed push-pull circuits in a polygonal geometry.

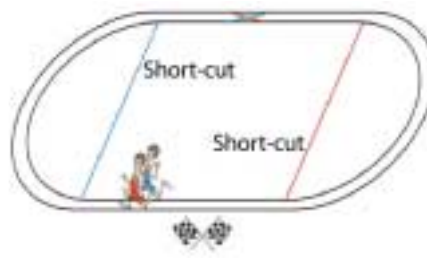

Figure 2a. The racetrack analogy.

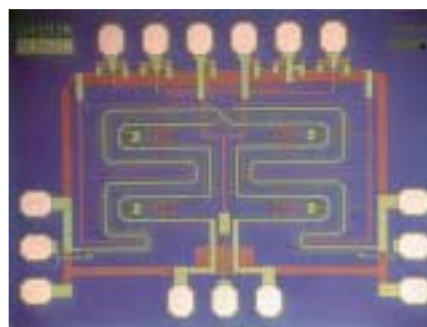

Figure 2b. A die photo of the 10-GHz distributed voltage-controlled oscillator using 0.35- $\mu\text{m}$  CMOS transistors with a tuning range of 12% and phase noise of  $-114\text{dBc/Hz}$  at 1-MHz offset. In addition to higher frequency of oscillation, the DVCO provides better frequency stability.



Each side of the square is a single amplifier consisting of a transmission line, two transistors, and input matching lines. This particular positioning of the push-pull amplifiers makes it possible to use a wide metal line as the drain inductor to provide natural low-resistance paths for the dc and ac currents to flow.

The four transmission lines are used as the primary circuit of a magnetically coupled active transformer. The output power of these four push-pull amplifiers is combined in series and matches their small drain impedance to the load. These four push-pull amplifiers, driven by alternating phases, generate a uniform circular current at the fundamental frequency around the square, resulting in a strong magnetic flux through it. A one-turn metal loop inside the square is used to harness this alternating magnetic flux and acts as the transformer secondary loop. This is where multiple signal paths converge. Using the DAT, a fully integrated watt-level power amplifier was demonstrated in a standard CMOS process technology for the first time, as shown in Figure 3b. The distributed nature of the DAT structure reduces the sensitivity of the power amplifier's efficiency to

the substrate power losses while providing a large overall output power using low-breakdown-voltage MOS transistors. The strong electromagnetic coupling between

multiple signal paths in a DAT necessitates an analysis and design approach spanning architecture, circuits, device physics, and electromagnetics.

These examples demonstrate some of the basic concepts of distributed integrated circuit design. The combination of multiple distributed signal paths working in harmony and a design approach covering several levels of abstraction allow us to achieve higher frequencies of operation, higher power and efficiency, while creating more robust systems.

Bringing this state-of-the-art technology into the commercial realm, substituting easily mass produced silicon-based circuits for the traditional GaAs-based circuits in use today in everything from cell phones to communications satellites, will further the revolution in communications systems that defines our modern era. **ENR**

*Ali Hajimiri is Assistant Professor of Electrical Engineering.*

There is more on Professor Hajimiri at <http://www.chic.caltech.edu>

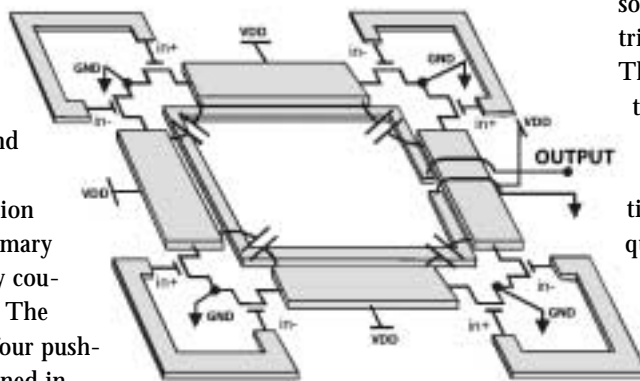

Figure 3a. The essential features of our distributed active transformer (DAT).

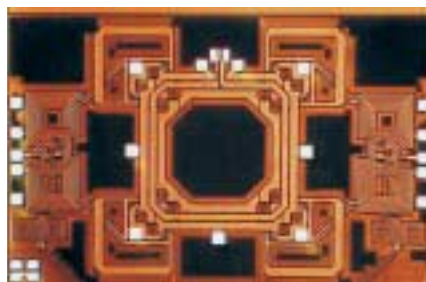

Figure 3b. A die photo of the 0.18- $\mu\text{m}$  CMOS DAT generating 3.6 W of power at 1.9 GHz into a 50- $\Omega$  load using a 1.8-V power supply, while achieving a power added efficiency of 51%. It is fully self-contained and uses no external components. The distributed nature of the DAT structure reduces the sensitivity of the power amplifier's efficiency to the substrate power losses while providing a large overall output power using low-breakdown-voltage MOS transistors.



## William Bridges: A Rare Combination Of Talents

by Amnon Yariv

W

illiam (Bill) Bridges, Carl F Braun Professor of Engineering, turned emeritus in July 2002,

thereby closing one chapter in a varied and productive life and career, and opening another. I ran into Bill in my second (his first) year at Berkeley in 1952. We have stayed friends and close professional colleagues to this date, so when asked to give an overview of his career, I jumped at the opportunity.

Bill was born in Inglewood, California on Thanksgiving Day, 1934. Bill lost his father at an early age. The vacuum left was filled by a grandfather and great uncle who introduced Bill to tinkering, building things—including amateur radios. Early on, he acquired that hands-on, “I can build anything” approach that would serve him so well as a scientist/engineer and as a teacher.

I still remember my first impression of Bill. I came from a background where to be good in math meant being theoretical and no good with your hands. Here was a kid who handled the tough Berkeley engineering courses with

ease, but who also could fix cars and radios. In addition, he was genuinely nice and gentle-mannered and unaware of the rare combination of his talents.

Bill graduated in 1956 with a BS in Electrical Engineering. He was among the top five in the Berkeley class of 5,000 and also the top engineering student. Now married, he chose to stay on for graduate school in Berkeley and pursue a thesis in microwave tubes (a technology still used in microwave amplifiers in communication satellites). Bill would finish his doctoral research under Professor Ned Birdsall doing pioneering work on instabilities in electron beams in a vacuum. These instabilities—spontaneous voltage and current oscillations—were thought to be the cause of much of the performance degrading noise in vacuum-tube amplifiers and oscillators. Their original work has been just rediscovered and used recently in Los Alamos and Russia for extreme high-power high-gain oscillators—one man’s instability is another man’s gain.

Bill received his PhD from Berkeley in 1962. After considering a whole slew of employment offers, Bill chose to join the Hughes Research Laboratory (HRL) in Malibu, California. HRL at the time was unique, and probably one of the most exciting research laboratories anywhere. Run essentially as a non-profit organization by Caltech, Berkeley, and Stanford PhDs, it provided a home to exceptional scientists who amazingly, by

today’s standards, were able to pursue fundamental ideas. The world’s first laser, the ruby laser, had been invented there by Theodore Maiman. Some early attempts at HRL to make He-Ne lasers (newly invented at Bell Labs) were unsuccessful and Bill was asked to help because of his background in tube and vacuum techniques. Before long, Bill found himself immersed in the new area of gas lasers, lasers in which the lasing medium is gas present in a mixture of some other gases and excited by an electric discharge.

Bill’s biggest claim to his very considerable fame occurred at this juncture. While trying systematically to understand the lasing of Hg, Bill tried mixtures of He-Hg, Ar-Hg, and other noble gases. In these experiments he observed a new and intense blue laser emission. After a process of substitution and elimination and very careful spectroscopy, which Bill learned on the fly, he was able to trace the lasing to the argon ion  $Ar^+$ . This would lead to the discovery of lasing in krypton and xenon as well, and to a new class of lasers, the noble gas lasers. It is difficult to work in any physics or chemistry laboratory in the world today without bumping into Bill’s “Argon Laser.” The invention of this laser was made possible by the unique blend of talents that Bill possesses: the insistence on understanding at the most basic level why something works, the hands-on ability to make things work, and the keen intellect to combine the two.

The following few years saw Bill become an internal “guru” at HRL; he was often asked to work on their most advanced and venturesome programs. These included gas-dynamic lasers, adaptive optics, and atomic-clock gas masers. But he was also being drawn more and more into management and away from the laboratory.

A Caltech Sherman Fairchild Scholarship during 1974–1975 provided relief from his management role. Bill spent most of the year teaching an optics lab that served to remind him how much he enjoyed teaching and interacting with students. It also convinced a group of us in Applied Physics and Electrical Engineering that Bill would make a splendid addition to the faculty. An offer was made and accepted and by 1977 Bill had joined Caltech.

One of his first projects was to set up and teach a demonstration class in optics, for which he built much of the equipment himself. His reputation as a teacher with a hands-on approach from his Fairchild Scholarship sojourn caused 70 students to register for the class—nearly a third of that year’s sophomore class. Bill’s hopes of secluding himself in the laboratory, however, did not quite materialize (which was partly his fault). He recognized very early that Caltech’s electrical engineering students could be better served. The lack of an official EE major in the curriculum with a set of required courses left students confused, and often resulted in students graduating without such basic EE courses as electromagnetic theory. Bill’s crusade to institute an EE major with well-prescribed requisite courses was highly successful, but it

also resulted in his becoming, a year after his arrival here, the executive officer for EE. Soon after his arrival, Bill’s inability to say no to worthwhile causes also landed him on the EE Search Committee, and subsequently on the Patent, Health, Freshman Admissions, and Undergraduate Academic Standards and Honors committees. He also became involved with the Society for Women Engineers as well as the Amateur Radio Club.

In a short span of three years Bill had become one of the most involved and effective faculty members, whose contributions extended well beyond his research program, as well as one of the most sought-after teachers.



O

n the research side, Bill switched gears at Caltech and started looking into extreme high-speed electrooptic modulators. These are optical waveguides “written” through selective doping through masks into electrooptic crystals such as  $\text{LiNbO}_3$ . When high-speed digital voltage pulses are applied to such waveguides they can switch light on and off. The work of Bill and his students helped turn this modulation scheme to the dominant method of launching bits into optical-fiber systems.

The involvement with  $\text{LiNbO}_3$  bore some unexpected, and to Bill, sweet fruit. Bill had been serving since 1986 on the board of a small company, Uniphase, which made small, mundane lasers. When the CEO started looking at new targets of opportunity, Bill encouraged the purchase of the  $\text{LiNbO}_3$  optical-modulator business of United Technologies. In a matter of a few

years, these modulators became one of the key devices in the quickly expanding technology of high-speed optical-fiber communication. In an amazing but separate story, Uniphase (now JDS Uniphase) became the world’s leading manufacturer of optical communications devices. Bill, who was paid “mostly in stock,” became “comfortable,” and was able with his wife, Linda, to build their dream home in the woods near Nevada City in northern California.

Bill’s talents and achievements have, of course, been noted by the world at large. Besides garnering most of the major awards in the optics and laser fields, Bill is among a very small number of people who are elected members of both the National Academy of Science and the National Academy of Engineering. He also squeezed in a presidency of the Optical Society of America.

What is Bill going to do now? Once the house up north is finished, he plans on dividing his time between Pasadena and the woods, traveling more, and finally, getting back into the laboratory. I personally was relieved to hear that a good fraction of his time will still be spent at Caltech. The school cannot afford to lose his splendid counsel and input.   

---

*The author, Annon Yariv, is the Martin and Eileen Summerfield Professor of Applied Physics.*

To learn more about Bill Bridges, visit <http://www.ee2.caltech.edu/People/Faculty/bridges.html>

What do the complex workings of a cell have in common with the relentless unrest of the New York Stock Exchange? Are these dynamic storehouses of information obeying similar laws in terms of the ebb and flow of information, and can they be modeled, analyzed and understood by a unified mathematical framework? Caltech is launching a new Institute-wide intellectual adventure with the creation of the Information Science and Technology Institute (ISTI)—drawing the curtain back, so to speak, on the nature of information itself, and redefining the way we approach, understand, and implement information science and technology.

## When You Come to a Multidimensional Fork in the Road, Take It: Information Science and Technology at Caltech

*Within the next decade, information at Caltech will be a unifying, core intellectual theme spanning the physical, biological, and social sciences, and engineering. Such a formidable, collective leap forward is the result of two idiosyncrasies: Caltech's long-standing and imaginative blending of traditional disciplines and the low one or two degrees of separation between disciplines, faculty, and students which allows exceptional people from seemingly disparate fields to work together naturally. Put another way: we're fabulously small, we engage in a lot of scientific gossip, and the standard departmental boundaries are all but invisible around here.*

*ISTI's interdisciplinary research, academic, and outreach agenda is large and will develop roots in each of Caltech's six divisions, with participation of more than 20% of the faculty, and nearly 35% of all students through curriculum. We aim to create a common language for the study of information, one that will stimulate fundamentally new thinking about problems facing not only the usual suspects (computer science, quantum physics, electrical engineering, applied physics, and applied mathematics) but also those not normally associated with information science and technology such as experimental economics, pure mathematics, and developmental biology. By approaching information science and technology from multiple levels of abstraction, we'd also like to figure out new tricks for atoms, light, molecules, cells, circuits, algorithms, and networks.*



Jehoshua Bruck

*What will be the outputs? Absolutely smashing scientific and engineering discoveries, students who'll go out into the world and (we hope) one-up their thesis advisors, and technological advances only yet imagined in our wildest dreams...*

*Such an ambitious program will involve two phases. The first is the creation of the research component, the wellspring from which the corresponding academic and outreach programs of the second phase will flow. And we need look no further than three words—multidisciplinary research center—for the formal mech-*

*anism for bringing people and their ideas together from each of the "six corners" of the Institute.*

*Over the last year, in an effort to define and help grow an IST community at Caltech, groups of faculty convened, conferred, and converged on a set of unifying principles for four new research centers that together provide the critical mass necessary to launch ISTI. Jehoshua (Shuki) Bruck, Gordon and Betty Moore Professor of Computation and Neural Systems and Electrical Engineering, chaired the IST Faculty Planning Committee, which issued its final recommendations in early January. The proposed centers, ultimately to be housed in a new building, are the Center for Biological Circuit Design (CBCD), the Center for the Physics of Information (CPI), the Social and Information Sciences Laboratory (SISL), and the Center for the Mathematics of Information (CMI). These four new centers will join the established Lee Center for Advanced Networking and the NSF Center for Neuromorphic Systems Engineering to form the initial core of ISTI. As ISTI matures, research advances and the natural dissolution of older research initiatives will drive the creation of new centers.*

*From these vibrant centers will emerge a unique academic program, the first of its kind in the country. The new undergraduate and graduate programs will combine engineering and science with a clear focus on information, and direct exposure to the central issues across the entire intellectual landscape. And finally, to create the broad societal impact commensurate with the outstanding research and academic components of ISTI, we will design and conduct a highly visible outreach program. Through executive, visitor, and industrial affiliate programs, we hope to supplement and share Caltech's contributions by collaborating with members from key academic institutions, government, and industry. Workshops, lectures, and summer schools will round out the menu for the continuing revolution in information science and technology.*

Listen in on the following four conversations among Caltech faculty engaged in thinking about what these new centers will bring to Caltech and society at large, as Caltech embarks on this unparalleled and profound exploration.

## Center for Biological Circuit Design: Soft Circuitry and Liquid Algorithms—

A New Bioengineering Frontier Takes Form

A Conversation with Niles Pierce, Paul Sternberg, Erik Winfree, and Barbara Wold

Biology computes, that is, living structures store, process, and communicate information in organisms and ecosystems. The CBCD is being organized to understand the form and function of these biological circuits and to develop the tools needed to design new and improved circuits.

**WOLD:** There is a computing revolution going on across the board in many areas of biology—from molecular, to cellular, to developmental and neurobiology. At an obvious level, the revolution is driven by rapid changes in the kind and amount of data we work with, beginning with entire genome DNA sequences and everything that now flows from them. The basic challenge is to turn data into real information, then turn that information into real understanding. At another level, biologists have long been interested in information in living systems—how it is encoded, stored, recalled, and transduced from one site to another. These are themes that the faculty in this Center will be addressing in a very particular way.

After talking to many of our faculty and colleagues, in and out of the Biology Division, we hit upon the idea of focusing on biological circuit design. In some sense, you don't really understand the properties of something until you can sit down and—from scratch—design it, test it, and see if it behaves as you predicted: have you got it right? I'm not an engineer, but I think that's a major engineering process, or at least an important one. Biologists have been, so far, quite timid about wholesale design. We go in and

tweak things a lot. We break things and see what happens. That's the heart of classical genetics. Or, we take things out of the cell and make them work in a test tube—that's biochemistry's challenge. So at this point, from all of our tweaking, the biologists have learned a lot about the molecular compo-

---

*...you don't really understand the properties of something until you can sit down and—from scratch—design it, test it, and see if it behaves as you predicted: have you got it right?*

---

nents of gene circuits. Similarly, neurobiologists know a lot about the cellular components of neural circuits that ultimately lead to brain function and behavior. In the middle are the people studying signal transduction—that is, how signals travel from the outside of the cell to the inside of the cell, or from one cell to another.

The state of the art is this: we know an enormous amount about what the circuit components are, and something about how they're hooked together. We know a good deal about how the inputs work, and, globally, what the outputs are.

But what gives a biological system its real properties—for instance, its robustness in the face of various kinds of insults? What are the dynamical properties of important circuits? How is information really encoded or stored by a given molecular or cellular circuit? Getting at these questions using a design focus is the core mission I see for the CBCD: it will take the fruits of all the research of past decades, combine it with the current revolution in biological information processing, and focus on circuit design. This is tremendously exciting, and central to deep understanding of biological systems.

**STERNBERG:** Another way to describe what we want to do is the “reverse engineering” of biological systems and circuits. But it's going to be much easier to learn how to do it with, for instance, a Model T rather than a Boeing 777. Organisms have been around for a billion years, making nature's designs incredibly complex and sophisticated. Even the simplest organisms are intricate integrated machines. They have embedded controls that are really hard to tease out. It's a lot easier to build something from scratch and then learn how to model it.

In my lab, we've looked at signal transduction and we've come up

with very nice models that are powerful. But when we go into the real cell, they fall apart, because every little detail has been tuned by processes of evolutionary selection to make it work. That means you really want to start very simple. That's where the synthetic approach comes in. To build biological circuits, we need to define components and interactions. We have to determine which components are really going to be robust. You can liken this to creating a system using Lego bricks. You want to have the equivalent of those bricks, and that takes a lot of thought. Right now, Niles Pierce, Steve Mayo, Frances Arnold, and their colleagues are thinking about how to make those components.

**PIERCE:** We have three different types of people at Caltech who are all working in areas that contribute directly to progress on this very challenging topic. First, as Paul said, we have the tool builders who have been working on components. Steve Mayo's lab uses computational methods to design proteins with enhanced stability or novel functions. Frances Arnold's lab, by contrast, uses directed evolution to obtain molecules with new or enhanced functions. Richard Roberts' lab has developed a novel approach for *in-vitro* selection to screen for molecules with particular functions. My lab works

on computational algorithms for designing molecular machines out of DNA and RNA. Erik Winfree's group is interested in biological computation and issues of how biological systems can be designed to

Mary Kennedy, Thanos Siapas, Jim Collins, John McCaskill, Ron Weiss, Tom Knight, and Barbara Wold, among others. So there is a diverse set of people working on component-level issues for circuit

design, creating synthetic circuits, or studying naturally occurring circuits. The latter have a deep understanding of how those circuits function and how they're structured. All three communities are well positioned, right now, to try to approach biological circuits from a synthetic point of view.

**STERNBERG:** There's a critical mass of talent, including researchers in the neural biology community—the Computation and Neural Systems program—who are thinking about how naturally occurring circuits work, and how one might like to design new ones. Because of the properties of the systems they study, they have a different view of how to analyze a complex circuit. Thanos Siapas and Gilles Laurent record information from multi-

ple places in one structure simultaneously. They are good at articulating this approach and figuring out how to apply it to other complex systems—for instance, in a cell. Bringing in their expertise and interests allows us to make bridges all the way from chemical engineering to brain neuroscience in this quest to design and understand biological circuits.



Clockwise from top left: Niles Pierce, Paul Sternberg, Barbara Wold, and Erik Winfree.

process information. Steve Quake, Jared Leadbetter, and Frances Arnold are collaborating on the design of cellular signal-processing circuits in bacteria. Finally, we have a number of biologists [here and elsewhere] who study the structure and function of naturally occurring circuits, including Mel Simon, Elliot Meyerowitz, Stan Leibler, Paul Sternberg, Eric Davidson,

Caltech is more than ready to make this very interdisciplinary, very ambitious goal happen. And again, it can only happen here, because in all the divisions you have people who are really good at what they are doing, of course, but also imaginative enough and interested enough to be able to learn other approaches. I think what will happen in the Center is that at the start, everybody will come in with his or her own ideas, leading to an incredible effervescence. Then we'll condense our focus on a couple of projects that seem tractable and seem to be the right way to learn to prove principles that will lead to new technology. The new technologies will then be applied in many directions and spawn new industries.

**WOLD:** One of the other things the CBCD will spawn will be an entirely new generation of students and post-docs with a worldview that is some interesting combination of all these inputs. Without the Center, a few students might make the interesting connections that biological circuit design requires. With the Center, and the concomitant "lowering of the energy barrier," so to speak, the path toward this kind of research training will be much more easily and frequently traversed. So the impact—through these people—ultimately goes far beyond Caltech.



**WINFREE:** One of the problems engineers face is understanding which aspects of a given compo-

nent are important and which are just implementation details, not really relevant to the function. This leads to new levels of abstraction. For instance, we ask: "Is this atom over here the critical atom, so I need to focus my attention down here at the molecular level? Is it

---

*Caltech is more than ready to make this very interdisciplinary, very ambitious goal happen.*

---

critical to the function or not?" Researchers try to understand that by making mutations, changing a moiety here or there, and so on. This is another approach for determining which parts of a system are important, and which are merely accidental. I hope that going through the design process will help elucidate this completely.

Many advances in biology have been driven by instrumentation.

---

*Programming with biochemical reactions rather than with logical "and gates" and "or gates" is a whole different beast.*

---

For instance, once people understood that a feedback loop coupled to an electrode in a cell could lead to something like a patch clamp, a whole new way to characterize biological circuits was born. It became possible to measure currents, I-V curves, and so forth. An entire range of experiments, previously

impossible, became possible. The ability to build electronic circuits and integrate them with biology brought to the table a new way of doing science. The possibility of building *biochemical circuits*—for instance, novel genetic regulatory circuits to hold the concentration of an enzyme at a constant level, or to trigger a reaction just at the right time—will provide an entirely new approach for understanding what goes on inside the cell.

One thing that excites me is thinking about the relationship between the concepts that computer scientists have developed and the realities that biologists are observing. Understanding the kinds of algorithms that biology has been exploiting, and the design space of those algorithms, is fascinating. Programming with biochemical reactions rather than with logical "and gates" and "or gates" is a whole different beast.

**ENGENIOUS:** What are the practical goals of the CBCD?

**PIERCE:** One way to encapsulate a long-range objective for the CBCD is to say that we're going to try to recreate the remarkable technology of the compiler. A compiler takes an algorithm written in a programming language and turns it into instructions that a computer can understand. Given a conceptual design for a circuit, we'd like to be able to "compile" a set of molecules that can be introduced into a test tube and be observed to function according to the principles for which that circuit was designed. This outcome would be tremen-

dously exciting not only for its biotechnological and medical applications, but also for the sheer challenge of working with a complex array of components to develop a design framework robust enough to produce working molecules and circuits. This goal sets a high standard, but I think we have a real shot at meeting it.

**GENIUS:** Will principles of evolutionary biology be useful in this work?

**WINFREE:** Exploiting evolutionary principles in the design process is already being done at Caltech. For instance, Richard Roberts does *in-vitro* selection to design protein sequences with functional properties. Frances Arnold applies directed evolution to both circuits and proteins. These are important tools. It will be interesting to integrate this “irrational” approach, where you try a bunch of things and select one that works, with rational, systematic design, where you put together a system based on your ability to predict how it will function.

**WOLD:** A hybrid approach is to design first, then subject the system to very rapid evolution for optimization. This allows you to see how close you were to optimal in the first place.

**WINFREE:** Absolutely. I think that’s an important approach, and the way you might design components—a particular protein, for example—by some kind of directed evolution, then characterize it, put it in your toolbox, and fit it into a circuit in a rational way. Then, per-

haps, do another level of evolution to optimize that circuit.

**STERNBERG:** Then you can look at evolution to see what’s worked—which components have been used

---

*...we’re going to try to recreate the remarkable technology of the compiler.*

---

in many circumstances, but have maintained their central character. Neurons, for instance, are very successful. Our neurons are the same as many other creatures’ neurons, but they’re wired together in different ways. It’s the circuit design that makes us different. That’s something that was discovered at Caltech, by John Allman and his colleagues, and elsewhere. Neurons are one type of component. At the molecular level, we have the G protein, a molecule that Mel Simon has been obsessed with for years. It

---

*What Caltech does best is getting fundamental ideas and technologies to a level where they can radiate out to the tech sector.*

---

acts as a little molecular switch or timing device. We could start with these known robust components and learn how to build things with them. But given the collaborations that will take place, each person’s research approach might be wonderfully and radically changed.

**WOLD:** That may be the most important bit of “evolution” from

our immediate point of view. We exert intellectual pressure on each other to look at a problem in a different way and to use somebody else’s point of view—intellectual evolution in action.

**STERNBERG:** And that’s why articulating and committing to a focus on designing circuits is going to change the direction of many people. There are a lot of our colleagues we think will be involved, but they don’t even know it yet...

**WOLD:** But we have faith that they will be attracted by the theme and know exactly what to do.

One last thing concerning potential practical outputs. Our greatest passion is for the deep underlying principles. At the end of the day, to us, a practical result would be having the compiler. But as viewed by many other people, that’s not a practical output. Certainly the implications of this work will have a significant biotechnological spillover. What Caltech does best is getting fundamental ideas and technologies to a level where they can radiate out to the tech sector.

**WINFREE:** And the possible technological implications here are not restricted to the medical or biological realm. The ability to program things and to automate tasks has profoundly affected science, engineering, and technology in the last 50 years, a very short time historically. Most programs exist in microprocessors, which are quickly becoming ubiquitous in our lives. They are in your microwave oven, in your car, in your digital camera. We know how to program and



exert embedded control over macroscopic electromechanical systems, and this has revolutionized technology.

Nature, through biological processes, has transformed the earth by exploiting algorithms and embedded control at the chemical level to fabricate cells, bodies, and ecosystems; to build forests from light and chemical nutrients, for example. Intellectually, we don't really understand how these things exert an influence over chemistry and organize it into meaningful constructs. Biochemistry is where we see most clearly that informa-

tion and algorithms are fundamental elements of the chemical process. Nature has polymers, like DNA, which contain information. The cell interprets that information as a program for directing its behavior. Evolution changes the program to carry out an incredibly wide range of functions. This is a technology that isn't just biological: biology is only one possible result of programming biochemistry. Working with atoms and molecules in systems will turn out to encompass a wide world, and is going to be very fun.

**WOLD:** Actually, at the end of the day, that's the point. We don't usually start with that. What's the goal of your Center? To have fun. But we know it will be...

---

*Niles A. Pierce is Assistant Professor of Applied & Computational Mathematics. Paul W. Sternberg is Professor of Biology and Investigator, Howard Hughes Medical Institute. Erik Winfree (PhD '98) is Assistant Professor of Computer Science and Computation and Neural Systems. Barbara J. Wold (PhD '78) is the Bren Professor of Molecular Biology and Director of Beckman Institute.*

## Center for the Physics of Information: The Impending Overthrow of the Silicon Monopoly: Revolutionary Substrates Unite!

A Conversation with André DeHon, John Preskill, and David Rutledge

Silicon is a superb computational substrate...but sooner or later it will run out of room. The CPI is devoted to inventing the new computational substrates, architectures, and algorithms for the computing devices of the future.



From left to right: André DeHon, John Preskill, and David Rutledge.

**PRESKILL:** We're kind of an odd mix of people, you know. I'm a theoretical physicist, Dave's an electrical engineer, André is a computer scientist. But I think we have some things in common. In those areas of overlap there's a potential for some really exciting scientific and technological developments. We know that the advance of our information technology, which has been dazzling for so long, is confronting limitations that come from physics and, in particular, from the size of atoms. And we don't know beyond say, a decade, what we are going to

do to continue the type of progress we've gotten accustomed to. It's going to require really new ideas. We don't know what. We don't know how we're going to get there. And that's what we're going to be thinking about in this Center.

There are a lot of ideas about exotic ways of manipulating information, but there's a tremendous gulf between some of those concepts and practice. In particular, I'm interested in quantum computing. If it comes to fruition, we'll see an amazing advance in the speed of computation. It's really exciting. We have these beautiful theoretical ideas about quantum computing, but we really don't have any definite idea about how to progress along the road that will lead us to advanced quantum computing.

**RUTLEDGE:** One thing that I think is interesting about the Center is its ancestry, so to speak. Caltech has a very good history of making fundamental contributions to the physics of small things and information. Three people that come to mind are Richard Feynman, John Hopfield, and Carver Mead. There's a great tradition. But recently Caltech has hired many outstanding junior faculty in different departments across the campus who are connected to this area. That's really Caltech's advantage.

We have the opportunity here to take some of the ideas being developed on the scientific, physics side to see if they really work in engineering products. That would require, for example, getting some of the ideas to work on a silicon integrated circuit. This vertical integration—from the theoretical up through the practical—will mean strong collaboration between scientists and engineers to get really neat scientific ideas transformed into practical devices.

**DEHON:** I think vertical integration on a higher level also means we'll be rethinking abstractions at many layers. Presently, we've got a very well-developed set of abstractions for designing computers and software on top of silicon. And we

---

*...the advance of our information technology, which has been dazzling for so long, is confronting limitations that come from physics...*

---

know "this is where we collapse into the gate level; this is where we build up some architectures on top of that; here is where we build the program; and then there are algorithms on top of that." There is a nice set of defined layers. On the other hand, when the rules change, the costs change, and really good engineers will be the ones saying, "Okay, these old abstractions are getting in my way." What's very clear here is that using some of the

---

*...really good engineers will be the ones saying, "Okay, these old abstractions are getting in my way."*

---

same interfaces and abstractions we have in the past will defeat the purpose. Silicon's been very reliable; things work because we're talking about a million atoms sitting in one place. But it's not clear whether we'll have that type of control with substrates where we will be working with individual (or very few) atoms. So that's going to force us to re-evaluate all of our models: what you use for computation, the programming language, and so on.

**GENIOUS:** So for instance, algorithms might not sit so high in

the hierarchy any more? They might be more embedded in the fundamental substrate itself in some way?

**DEHON:** I would believe that.

**RUTLEDGE:** Also, with smaller numbers of atoms, you really have to deal with errors in a fundamental way...

**DEHON:** ...because there are some things that may be less hidden. One of the things you try to do in good engineering abstraction is hide unnecessary detail and bring up the dominant effects you need to optimize. I think the dominant effects are probably going to shift and change. There are different things we'll need to bring to the attention of the engineer.

**PRESKILL:** Maybe the concept of a general-purpose device will be less central than it was in the past. Some physical systems may be better suited for certain applications than others. We should be willing to let blur those layers which had served us very well in the past—substrate, architecture, and algorithm—and to think things through from the start. Error correction is probably the best example. In quantum computing, this area is one of my major interests. For instance, we had to rethink what type of physical system would potentially be very resistant to errors. Some technologies with lots of good features may fail in that regard. So quantum computing just won't be a possibility for certain types of physical applications.

**DEHON:** The deeper I got into the VLSI work I started out with, the more I began to really understand that the underlying physics of the substrate was inseparable from the most efficient architecture possible, and the eventual implementation.

And as VLSI got smaller, the landscape changed. Wires got more expensive, for instance. Ultimately, our computations do depend on the physics we use and the structure of the physical world. After looking down at VLSI for so long, it's good to just look up and realize scientists are working with some amazing new phenomena: carbon nanotubes, experiments trapping a single atom. So you say to yourself, "How can we harness these things?"

For me, a central issue is understanding computational cost structure. When the cost structure changes things radically, the nature of the solutions changes as well. The general-purpose processor that made a lot of sense in VLSI just doesn't make sense for these new things. We are off in a completely new playground, which is very exciting for an architect. Caltech is a place that allows me to think sometimes at the circuit level, sometimes at the manufacturing level, sometimes at a mathematical/statistical yield level—all over the map. And for something new like this, where no established discipline exists, it's important to gather people from various areas who can think broadly about the issues. This is what the CPI will accomplish.

**PRESKILL:** We're searching for new paradigms, something that Caltech does especially well. Maybe we won't be the place that actually builds the next revolutionary generation of devices, but I think what we should aspire to is becoming the world's leading institution for laying the scientific foundations which will be the basis for information technologies of the future—we will be generating absolutely new ideas.

And training students so they have the broad background that's necessary to get the big picture.

**ENGENIOUS:** How will the structure of the Center facilitate breakthroughs?

**RUTLEDGE:** We're interested in creating an environment conducive

---

*...with smaller numbers of atoms, you really have to deal with errors in a fundamental way...*

---

to professor and student interaction. And we're anticipating that there will be a new Information Science and Technology building as a result of the fundraising campaign. University professors are prone to being trapped in an area; this is a good way to force them out into new things.

**DEHON:** People like Bill Dally [PhD '86; now Professor of Electrical Engineering and Computer Science at Stanford University] and others came to Caltech in the early '80s because it was *the* place for VLSI. And that's really what we want—for Caltech

---

*It's so important to have the freedom to be daring...*

---

to be *the* place for the next revolution in novel computing. There's a great deal of uncertainty about what's going to happen in this area, and yet that's what makes it exciting. What's going to happen at the chemical level? At the biomolecular level? At the quantum level?

Look at this from a student's perspective. I maintain that our current and future students will go out into the world and have the same impact the Caltech VLSI students are having now—maybe even more so if we can get students from every area to interact with each other. For example, a student comes here to study molecular electronics, but this area doesn't exactly pan out. However, the real benefit will have come from interacting closely with other people doing perhaps biomolecular and quantum work, and from being taught how to think broadly about these areas. I think our students will certainly be in a position to found, transform, and lead the industry.

**PRESKILL:** The students are really the key. Caltech should be *the* place, the number one place, that a student thinks of if he or she is interested in the future of information technology in the long-term. Actually André and Erik [Winfree] did a great thing this summer—they were involved in the Computing Beyond Silicon Summer School, which attracted people from all over.

**DEHON:** We had 45 students for four weeks and 12 guest lecturers—the top people—coming from different institutions and intellectual areas. It was really something.

**ENGENIOUS:** How did the students deal with this new conceptual framework?

**DEHON:** It was interesting because it's not a "done thing," there is no orthodoxy. The students

[continued on page 27]



# Computing Beyond Silicon Summer School

Or How I Spent My Summer in Pasadena

There are revolutions at hand in the way we understand and implement computation, driven by an awareness of impending barriers to VLSI scaling and new understandings of the physical world. This fundamental shift in perspective allows us to contemplate engineering computational substrates at the molecular and atomic levels. To develop and exploit these new substrates will require an intimate understanding of both the physical substrates and the nature of computation, as well as the relation between them. Research and researchers whose competencies span across the disciplines will be necessary to drive progress in this area of novel computational substrates...

...Thus they read the opening paragraph of the announcement for the Computing Beyond Silicon Summer School (CBSSS). Coordinated by André DeHon, assistant professor of computer science, and Erik Winfree (PhD '98), assistant professor of computer science and computation and neural systems, the program brought together leading research faculty and 45 outstanding undergraduate and graduate students from many disciplines and institutions across the country (including Caltech). Part boot camp, part pleasure cruise, CBSSS served as an intensive four-week introduction to the emerging fields of molecular, biomolecular, and quantum computing.

Lectures, reading assignments, and a paper and presentation project kept the students active. In between all this, students seized the opportunity to hang out with the guest lecturers, Caltech faculty, and each other. They came, they learned, they met future collaborators—and they had fun. A potent combination. And of course, ditto for the faculty and guest lecturers...

As a prototype of ISTI's outreach program of summer schools, CBSSS's unique collection of people and ideas in one place at one time points to the future of Caltech as a hotbed of research in novel computational substrates.

For more information on who was there and what they did, go to <http://www.cs.caltech.edu/cbsss>

The CBS<sup>3</sup> students gracefully posed for "mug shots" for posterity. To engage the students beyond the lectures, the CBS<sup>3</sup> faculty asked them to self-organize into small project teams to expand on issues related to or motivated by the subject matter presented in lectures. The students had roughly three weeks to focus in on a topic and put together a brief report. See <http://www.cs.caltech.edu/cbsss/report1.html> for the resulting collection of student reports. Almost none of the students were "experts" in the issues they studied when they entered the program. Nonetheless, these reports show that the multidisciplinary teams assembled were able to dig deeply into a number of interesting problems and point out some promising directions for further inquiry.

[continued from page 25]

definitely went through a little mind expansion. There were EE students who thought [the EE framework] was the only way the world works...and in some cases biology students who didn't at the outset realize that maybe computational complexity meant something to them. All of them were challenged and out of their comfort zones. I think many of them had the experience of "Wow, the world is bigger than I thought it was." There is an opportunity to do interesting work at, for instance, the intersection of computer science and biology.

**PRESKILL:** And in some ways, it's easier for students than it is for us, you know. For me, the work I do at the interface of physics and information science seems kind of "out there," novel and daring. But to my students, it seems very natural. Those are the things they're interested in. Combining computer science and physics is second nature for them.

**GENIUS:** Caltech seems to have both a deep intellectual reservoir and a smallness of size that allows us to attack these problems much differently than anybody else. Are there other universities that can do what you anticipate doing?

**RUTLEDGE:** Smallness is a part of it. Caltech feels the same size as the entire EE department at Berkeley. There, someone "far away" from you intellectually meant someone that was making superconducting detectors in the electronics department. However, there are a lot of good places out there, and a lot of competition.

**DEHON:** Certainly MIT has the breadth. On the other hand, it's a

big place—with something happening in the Media Lab, and then there are people over in the AI Lab, far from folks in Mechanical Engineering. So you know, maybe it's a little bit harder to get coherence between the groups.

---

*We are off in a completely new playground...*

---

**GENIUS:** What is the one thing that excites you most about the Center?

**PRESKILL:** Well, from my own parochial point of view, I'm excited about making quantum computers a reality. It's just one of the emerging frontiers. If something like the Center for the Physics of Information can make that possible, I think that's very exciting.

**DEHON:** The Center will really allow us the opportunity to build critical intellectual mass. My students and I can sit there and ask each other questions, but having the ability to work with people from other areas thinking about the same problems will be powerful. The new solutions will create new abstraction hierarchies and new ways of decomposing problems. Things will not be the same as they were. Let's think out of that proverbial box and come up with some wild ideas.

**RUTLEDGE:** I see two things. One is the opportunity to work with people across a wide range of disciplines in a serious way. And the second is consistent support. I've run government centers, and it's astonishing how much of your life gets taken up by requirements and crazy things that change right

in the middle of established projects. Just to get out of the kind of environment where you're told what to do every two months is liberating.

**PRESKILL:** Absolutely. It's so important to have the freedom to be daring, not to have to defend the project on the basis of some short-term goal, some milestone event.

**RUTLEDGE:** I want to mention that junior faculty will be instrumental; they have already contributed in fundamental ways to getting things started. People like Erik Winfree [PhD '98], Ali Hajimiri, Hideo Mabuchi [PhD '98], André of course, and a handful of others.

**PRESKILL:** Yes, I think that's pretty good evidence that we're on the right track. Looking around campus and seeing so many young faculty involved in exciting projects at the interface of physical science and information science tells me that we are in a good position to live up to the legacy of Feynman, Mead, and Hopfield. **E N E**

---

*André DeHon is Assistant Professor of Computer Science. John P. Preskill is the John D. MacArthur Professor of Theoretical Physics. David B. Rutledge is the Kiyo and Eiko Tomiyasu Professor of Electrical Engineering.*

# Social and Information Sciences Laboratory: Markets and Other Noisy Human Artifacts—Can Computation Bring Them Out of the Bronze Age?

A Conversation with Yaser S. Abu-Mostafa, K. Mani Chandy, and John O. Ledyard

Social systems such as financial markets, political processes, and organizations aggregate and disseminate immense amounts of noisy information—but can this be done more efficiently? And can new, innovative structures be invented with the assistance of more sophisticated information technology? SISL will be exploring these and related issues.

**ABU-MOSTAFA:** There is an abundance of data and an abundance of computational resources in the world, yet our ability to manage these resources, to be able to look at data and efficiently extract the correct information, is limited. Highly distributed, data-rich, and generally unstructured, the world's financial markets seem to work well—remarkably well given the loose structures and lack of supervision—but they can be improved. The players in the markets are individuals, institutions, sometimes simply computer programs. They are looking at pieces of information that may be different from one source to another. They're all interpreting information differently. They have their own ideas and preferences regarding risk, value, volume, etc. Eventually, all of this is aggregated in global quantities like price, volatility—things of that sort. So a basic understanding of how such a general system results in efficient information aggregation is very important for two fields: economics and engineering. On the economics side, we would like to better understand markets and eventually be able to design markets. Once we do that, we can design markets in different arenas where there are no markets now. From the engineering perspective, we're interested in learning from the principles of how markets work how to generally manage distributed information and be able to aggregate it in a meaningful way.

**LEDYARD:** Economists would suggest that perhaps they know

something about markets already, that 200 years of study have produced remarkable insights about them. What's of importance in this Center, however, is the role of technology in the way markets operate.

---

*The question is whether we can leverage new advances in information science and technology to design new markets.*

---

There are barter markets, which have been around for thousands of years, which are not very efficient. The information technology underlying the New York Stock Exchange is still primitive in that humans are crucial at many points in the process. Many aspects of markets work wonderfully. If I'm fixing my house and I need a nail, I know I can go to the hardware store, and the nail is sitting there waiting for me. How did they know I would need a nail that day? It's not centrally planned. It's not managed the way engineers like to manage things. It's dispersed, disorganized, decentralized, but it does compute some pretty incredible things.

There are other pieces that don't work very well: supply chains, for instance, and public good kinds of problems. Markets don't work very well in these cases, partly because there aren't very many participants. They're very specialized and may not have much volume, so you can't rely on immediacy. The question is whether we can leverage new advances in information sci-

ence and technology to design new markets. Economists have generally attacked these problems assuming computation was free and easy—which it's not. Bringing the reality of information processing into market design is really important. The role of SISL is to bring the expertise of engineers and information scientists together with the expertise of economists—each has something the other doesn't. Working together, something really special will emerge.

**GENGENIOUS:** Will you be inventing new computational tools to deal with these problems?

**CHANDY:** At this point, I don't think we really know. That's why SISL is so interesting. From my point of view, the research of this center will bring "power to the people." Economic power has two parts: resources and information. Information technology today is at a place where one half of the economic power equation—information—is widely available. And this represents a significant dispersal of power from the few to the masses. I'll give you three examples of how this is going to change your life.

When the defense department wants to buy planes, it puts out a request for proposals, companies respond, and they finally choose a plane. DOD can afford to do that because DOD budgets billions of dollars for a plane. If you want to buy a car, you don't have the same flexibility. You don't request proposals for cars that fit your specifications. Nor, if you want to travel,

do you put out a request for proposals for tours with certain specifications. You can't do that because the cost of the transaction is high. But apply computational resources to this scenario, and things will change dramatically.

The second example is futures markets. We are familiar with the futures market on things like wheat, oranges, pork bellies, and so on. But what if there were a futures market on services like carpentry, plumbing, and electrical work when you add on to your house?

The third example is the creation of financial derivatives. Today, large financial services companies create financial derivatives tailor-made for companies doing ship-building in Poland, for example. Financial services companies create custom-made derivatives and sell them for lots of money. But with the kind of technology we will develop, companies will want to sell you derivative products for yourself based on your personal situation.

So these are a few examples of how the Center's research will help economic power devolve to "the people."

**LEDYARD:** Here's a sort of common theme in the story: let's say you want to build or buy something, a car or house or vacation. Today, you have to go to somebody who's packaged everything up without your particular needs or desires in mind. You can have people specially build your cars for you, specially build your house, but it's expensive. With computational capability, you can allow people to express what they really want to buy in a marketplace. So, rather than hiring a project manager to build your house, the computer organizes schedules, locks in the



From top to bottom: Yaser Abu-Mostafa, Mani Chandy, and John Ledyard.

futures contracts on carpenters, masons, roofers, and locks in a schedule. This is going to require some interesting theoretical work in terms of how you capture what are essentially "metaphorical" ideas—the idea that I want a house overlooking a lake, with three stories, etc.

The classic example of where this gets mishandled is the California electricity market. That was a designed new market. Somebody said "Let there be markets," and *voilà!* They did that in Russia and it was a disaster because they forgot they needed banks and property rights and various other things. In California, they forgot to integrate engineering, electricity, and the laws of physics with the market. They also made some bad assumptions about how people behave. There's been research, a lot of it at Caltech over the last 30 years, which could have prevented this problem from occurring. Simon Wilkie had a very nice article in *Engineering and Science* [Economic Policy in the Information Age, *E&S*, Vol. LXIV, No. 1, 2001, page 28] on just this problem. Engineers like to control

---

*Designers of distributed systems can control the rules of the game, but they cannot control the players.*

---

everything. Economists hate to control anything. Integrating these two kinds of approaches is going to be interesting, but it's required for a successful energy market. Give SISL up to ten years, and we'll pull it off.

With experimental economics, we have a way of demonstrating to

people how these things really work. We can actually bring science to bear on it. The combined energies of those working in this Center will create an intellectual core that anybody working in these fields simply won't be able to ignore.

**ABU-MOSTAFA:** I'd like to add something to the idea of exotic derivatives: one of the biggest advantages of having the computational technology to price these things is being able to communicate the derivative to so many players, thus creating a commodity. It becomes a real market—a place of exchange between buyers and sellers—because of the number of players and because of their ability to come to an agreement on price and to communicate instantly.

**CHANDY:** John said that engineers like to control things... but a true distributed system is one in which you don't know the participants, or even how many there are. Designers of distributed systems can control the rules of the game, but they can't control the players. So there are two parts to a distributed system: the visible hand, or

---

*Engineers like to control everything. Economists hate to control anything.*

---

the rules by which all the participants play, and then the invisible hand—how many participants, and how participants operate provided they play by the rules. Markets are beautiful examples of this, and we need to understand better how we get global behavior from these policies. This is very much an engineering problem.

**LEDYARD:** The process Mani is describing is what economists call

mechanism design. It's also very much an economics problem, where we recognize the incentives people have to follow the rules or not.

**GENGENIOUS:** What other Caltech faculty do you anticipate being involved?

**CHANDY:** In computer science, there are two relevant areas: applying economic principles to distributed systems, and applying technology to economic principles. For the first part, we have Steven Low's work on the internet and algorithms, and also John Doyle's theories on control and robustness applied to non-traditional applications like markets.

**LEDYARD:** We have been using markets as examples, because many people have contact with markets. But the same conceptual structures and questions arise in issues of voting and elections, committees, and organizing large organizations. In my Division, we have Tom Palfrey working on political processes. Peter Bossaerts studies the dynamics of financial markets and the process of price discovery. Charles Plott studies information aggregation processes. Matthew Jackson does fundamental research on networks. All of them will be involved, as well as others.

**CHANDY:** We will also work with people from the Center for the Mathematics of Information. We share an interest in the growth of data, the extent of data. Essentially, data come in three forms. There are structured data, like the price of a car. There are totally unstructured data, like news about an explosion in Azerbaijan near an oil well. And then there are semi-structured data, for instance, auction information like you would find on E-Bay. All three kinds are increasing everyday,

so the work of that Center—creating efficient representation choices—will be useful to the work of SISL.

**GENGENIOUS:** This work, taken as a whole, sounds like it could be an entirely new intellectual discipline.



---

*If we knew what would happen two years from now, it wouldn't be research.*

---

**LEDYARD:** It has the potential.

**ABU-MOSTAFA:** When you design a research enterprise like this, you have to have a gut feeling about it being special. But then these things create a life of their own. If we knew what would happen two years from now, it wouldn't be research. Once the collaborations begin, who knows what can happen? We've been discussing markets because they are tangible, and have real and immediate impact on people, but there is a wide range of applications for this research, including the organization of corporations, the health-care system, etc.

**CHANDY:** I really believe that SISL will have a direct impact on society, on ordinary people in addition to large institutions. This confluence of economics and information technology will impact everybody.   

---

*Yaser S. Abu-Mostafa (PhD '83) is Professor of Electrical Engineering and Computer Science. K. Mani Chandy is Simon Ramo Professor and Professor of Computer Science. John O. Ledyard is Allen and Lenabelle Davis Professor of Economics and Social Sciences.*



## Center for the Mathematics of Information: Information Theory Revisited: Mathematicians and Friends Tackle the Whole Enchilada A Conversation with Emmanuel Candes, Michelle Effros, and Pietro Perona

Mathematics has provided the foundation for virtually every major technological advance of human society. And now, there is a fundamental need to rethink the meaning and scope of computation, information gathering, and extraction. CMI will provide a home to the dedicated community of mathematicians, engineers, and scientists concentrating on developing the key mathematical ideas necessary to take information science forward.

**EFFROS:** There is a lot of excitement in research at the boundaries between traditional areas. The thrusts of ISTI reflect that excitement. One way to cross traditional boundaries is to focus on the applications of information science. Another way is to work on the topics that different information science



From left to right: Emmanuel Candes, Michelle Effros, and Pietro Perona.

applications share—which will be our approach. The CMI is focused on understanding the essential nature of information itself, the common properties shared by information in all of its physical forms and applications. We hope to learn how to collect, quantify, communicate, and manipulate information efficiently. In studying the mathematics of information, we

will bring together mathematical tools from communications, statistics, signal processing, and computer science with those developed across a wide variety of applications and build a shared foundation for studying information science.

Over the past 50 years, practical problems in communications, controls, and electronics have benefited enormously from break-

throughs in mathematics. The job in the information sciences is by no means done. Roughly, communications looks at bandwidth, controls looks at feedback, and computer science looks at computation. What is needed for today's more complex systems, whether natural or designed by people, is some way of capturing these things together and understanding how they interact.

*Representation choice* is one example of an area to investigate. Imagine that you have raw bits of data, or raw signal, and you want to extract from that some core meaning. Many fields have looked at the question of how to go from raw signal to information, but so far none have entirely automated the process. Humans are still critical in extracting meaning from data. Whether it's patient statistics collected by the Center for Disease Control in an attempt to identify epidemics early, or weather patterns tracked by the National Weather Service to warn people about impending storms, or genetic information gathered by researchers trying to understand patterns associated with heredity and disease, the quantities of information are enormous and the need for people to be a central part of the information extraction process is a critical bottleneck for advancement.

**PERONA:** The more we are able to dig into data and make sense of it, that is, transform data into information, the more powerful we become. The more efficient these processes are, the better we can make all kinds of important decisions—medical, economic, technological, and so on. Humans are built in a way that they spontaneously try to organize information and make sense of it. But machines are not built this way. There is an amazing amount of clutter out there in the world. We need to find out how to automate this process of

easily understanding which features are the important ones—and which to ignore.

**CANDES:** Humans use representations all the time. Look at the history of simply expressing numbers. The Romans came up with a

---

*There is...a fundamental need of rethinking the meaning and scope of computation, information gathering, and extraction.*

---

numeration system, but they had to give it up because it was not really efficient for calculating. If you try to add two numbers in the Roman system, it's a complete mess. That's why the Arabic numeration system was adopted, because it's handier to perform more complicated tasks. Now we have digital computers that use a binary system—only 0s and 1s—which makes addition, subtraction, multiplication, and division easy. This concept of representation is really critical to scientific thinking. For a given problem, you really want to find the correct representation—the one that makes a set of specific tasks completely trivial.

**PERONA:** Representations are not self-contained, they are finalized toward certain tasks. On one side we have the data, on another side we have prior knowledge about the world, and on the third side of the

triangle is the task. All three determine which representation should be used for a given problem. This is one of the big themes for the Center. For instance, my colleagues here at Caltech are studying the brain's different representations of the physical space around a person. Photons create an image that is captured by the retina, and then objects in the image are assigned retinal coordinates. Next the objects are expressed in head coordinates, and then in body coordinates. All of these different representations are useful. If I move my eyes, I want to know where the object is in respect to my head or my body, because my eyes have to move with respect to the head but I want my representation to be invariant with respect to that motion. If I move my hand to rub an object, the object has to be represented in world coordinates so that I can find it both with my hands and my eyes. The brain makes at least two different versions of geometric representations of the world. We don't know for sure that these representations are cartesian either. The problem is made more complex in that there may be several representations of the same data that need to be coordinated—this is another big theme for the Center.

Attention and awareness is another related problem—organisms pay attention to only fragments of the sensations transmitted to the brain, because it is the most efficient way to operate. When

confronted with practically infinite data, how do we know what to pay attention to? How do we shift our awareness? Several researchers in the Computational and Neural Systems option are dealing with the engineering issues behind awareness and will play a big role in the CMI.

**EFFROS:** Many people on campus are focused on representation choice. Some are concerned with vision, some with attention and awareness questions, and we have computer science people thinking about representation choice for the purpose of being able to do certain kinds of computations. The CMI will bring all these electrical engineers, computer scientists, and applied mathematicians together to tackle the foundations, the fundamentals of representation choice independent of the realm of application.

**CANDES:** I'd like to emphasize the timeliness of the Center. It's clear that scientists and engineers are engaged in acquiring massive data sets—in many areas of biology, bioengineering, and finance, many people are involved in massive data collection. It's clear that any kind of progress we make in the area of data representation will have a huge impact across many sciences. And though we're not the first ones to think about data representation, we

do feel that existing representations are somehow limited. There's a whole world out there of new representations that we would like to explore systematically. Any major advances that we make will be useful to other key players in the other ISTI centers.



**EFFROS:** What is the smallest amount of computation I can use to perform a particular task? My own field of communications or information theory focuses primarily on the quantity of information, whether you measure that as bandwidth or just as the number of bits that you need to represent some particular piece of information. Controls researchers focus on feedback. To think about how these different resources interact or trade off

---

*There are people all over campus who are thinking deeply about the mathematics of information. The goal in many senses is to bring them all together.*

---

is fascinating to me. If I'm working on a control system, say a distributed control system where I have a bunch of different devices all trying to work together to perform a particular task, I care about many things. I care about how many

computations each one of them needs to do separately. I care about how much communication between them is necessary to make the system work. I care about how best to use feedback. I care about representation choice. And I care about all of these things *simultaneously*. We are now at a point where it is, I believe, critical to figure out how to put all of these pieces together. So in information theory, the traditional view has been to look at how many bits it takes to communicate or store information, but the computation resource has been considered to be unlimited. You can have as much computation and delay as you want, but feedback is going to be a problem. These other resources were allowed to be unlimited so we could see where the critical points were in the one resource on which we focused. If you look at these other fields, they've done the same kinds of things. However, researchers in each of these fields are now realizing that we really need to take all of the resources into account.

Taking advantage of Caltech's small size and cross-disciplinary nature, we think that we can make real progress in putting these things together. In trying to understand, for example: is there a dynamics of information? What would the dynamics of information look like? Is there a conservation of information? What are the properties of

this new resource of information? Do they parallel the properties that we have in the physical sciences?

We have been building on Shannon's work for 50 years. But Shannon made assumptions. He did not constrain the amount of computation and he did not constrain the amount of delay. He just said, "Let's look at how many bits it takes," either to communicate through a noisy channel, or to store information. He captured one resource with incredible clarity and beauty by abstracting away many of the other resources that are critical.

**ENGENIOUS:** Could this Center reinvent the fundamentals of information theory, in a sense?

**CANDES:** If you allow me, I would like to formulate a more modest mission.

Every single field of scientific research is called upon to develop novel tools to process the information contained in massive datasets. While many aspects of these advances are going to be field-specific, it is clear that these challenges cannot be answered only in a peripheral manner. There is, in fact, a fundamental need of rethinking the meaning and scope of computation, information gathering, and extraction. From many endpoints of scientific research comes the solicitation to redefine our approach to information processing. Such fundamental paradigm change can, however, happen only if we invest a

considerable amount of resources in theoretical thinking centered around information. In short, our Center will create an environment, a home if you will, where these things can happen.

---

*...this is the place where we destroy all the boundaries between disciplines and even the concept that the disciplines need to exist...*

---

First, the Center will create the opportunity to deploy mathematical ideas, theories, and algorithms in information technology; to import new challenges into mathematics; and to create new mathematical theories and new mathematical tools via these interactions. Second, the Center will strengthen existing interactions and create new bridges between mathematical science and key areas in information technology. And third, the Center will help train a new generation of scientists in this emerging interdisciplinary area.

**EFFROS:** It's not that there's something wrong with the pieces that are there. But it's as if we have a few pieces of the puzzle that only give us focused pictures in certain realms. We're missing the big picture that puts it all together into a unified whole.

**PERONA:** You could take a more top-down view and notice how, in

the past century, technology delivered systems that were extremely effective at doing one thing. Think telephones, personal computers, automobiles, airplanes. All of these things are well designed and deliver the goods. They have changed our lives. Nowadays, things are being integrated and connected so you have telephone sets that become PDAs and computers; and automobiles that include telecommunications. And this is just the beginning of ubiquitous networking. These systems are increasingly complex. However, they're completely stocked with software that was designed 30 years ago. Unfortunately, we don't know how to design these integrated systems; we cannot guarantee that they will be robust to viruses and software glitches or that they will be stable and will perform according to plan.

A big theme in this Center is coming up with key mathematical ideas that will allow us to think about large, complex, distributed systems that include computation, include control, include communications, and still be able to deal gracefully with the inevitable software bugs, hardware problems of all sorts, and human errors. They have to keep working. Humanity depends on these systems. We are far past the point of simply needing the water well and the chicken and a tree hanging with fruit to live. If the internet goes down for a week, I think the world will stop. So the design of complex, robust systems

will be another important research area for the CMI. To do this, scientists from different disciplines will have to come together, transcend their respective disciplines, and broaden the scope of their research.

**CANDES:** Absolutely, and at the same time we want to rethink computation, particularly large-scale computation. A trivial answer to the large-scale problems is: give me more flops. Here is an area where mathematics could play a role by providing a more efficient data structure through more efficient representations of operators for calculation.

There's another very interesting avenue that we will explore—while the world we live in is continuous, and we have the laws of physics formulated in a continuous way, computers are only able to handle equations and sets of data that are discrete and digitized. So if you're looking at numerical schemes, or if you digitize an equation, you have violated a lot of physical conservation laws that nature prefers to be preserved. How can you think really discrete all the way through without violating physical laws in your end results? That's a topic people will gravitate around, and that scientists at Caltech have already started attacking. Squarely addressing this challenge will be critical for moving beyond this limited, digitized computational view, to one that takes into account that the real world is



continuous, multi-scale, dynamic, and complex.

**PERONA:** We hope the Center will bring the pure mathematicians at Caltech in contact with the technologists. We will be working very closely with the theorists in the physics center [CPI] as well.

**EFFROS:** Making that connection between pure mathematics and applied mathematics is critical. You would be amazed how broadly our theme sweeps. There are people in economics, humanities, and social sciences who are worrying about the mathematics of information. There are people all over campus who are thinking deeply about the mathematics of information. The goal in many senses is to bring them all together.

**CANDES:** I'd also like to emphasize that the CMI will provide a real link to and between the other ISTI centers. ISTI will bring the divisions of Caltech together in profound ways, and this particular Center will be the glue for ISTI.

**PERONA:** At the beginning, creating this Center felt like a construction. But now it feels like an inevitable fact. It seems impossible not to have thought about it a little bit earlier and it seems impossible that it will not exist. I see signs, all over the country, that the best, young creative people in every area that deals with information are just

bursting out of the seams of existing fields. And this Center is going to capture them. We hope to attract the best talent in the country, both at the level of graduate students and at the level of young faculty. They will want to come to Caltech because this is the place where we destroy all the boundaries between disciplines and even the concept that the disciplines need to exist—we're focusing on the real problems of today.   

---

*Emmanuel Candes is Assistant Professor of Applied and Computational Mathematics. Michelle Effros is Associate Professor of Electrical Engineering. Pietro Perona is Professor of Electrical Engineering and the Director of the National Science Foundation Center for Neuromorphic Systems Engineering at Caltech.*

## Sensing and Responding: Mani Chandy's Biologically Inspired Approach to Crisis Management

**O**rganisms receive streams of information from their senses, yet they manage to avoid information

overload and system breakdown by instantaneously aggregating information to identify threats and opportunities, and responding appropriately. Organisms are “sense-and-respond” systems that detect and respond to important events in their environments. Abstracting this relationship of organisms to their environment and turning it into a computer-based information system was the challenge that Mani Chandy, Simon Ramo Professor of Computer Science, set for himself almost a decade ago.

What he came up with could be thought of as the inverse of a traditional database: rather than repeatedly accessing well-defined static data structures with different queries, imagine data that constantly change, have no well-defined structure, but questions about the data that are more or less constant. You can liken this to an organism’s day-to-day stance to its environment—organisms get continuous streams of data, with varying structures and formats from their senses, but the conditions that define threats and opportunities change slowly. Occasionally there are “events”—sudden, dramatic, sometimes catastrophic happenings that require immediate response.



Organisms that respond to non-events waste energy. Organisms that don’t detect threats and opportunities in the environment don’t survive.

In 1998, Chandy took an academic leave from Caltech to start iSpheres, a company devoted to creating information systems for crises management. In the aftermath of the TWA 800 disaster, Chandy was inspired to develop a system so that all kinds of information (weather reports, emails, engineering data, police and fire department responses, and so on) could be accessible and useful for rescue workers and later, investigators,

responding to the crises. This idea was the seed that led to iSphere’s eventual products: decision-making systems for financial and trading institutions, manufacturing concerns, and corporations requiring a “sense-and-response” approach to tremendous amounts of unpredictable data in all sorts of formats and configurations. The software had not only to duplicate the “sense-and-response” functions that humans bring to decision-making, but also to amplify human capabilities, in both the amount and types of data sensed, and the time it takes to respond.

Chandy began working on this biologically inspired, inverse database problem in 1992/93, but in 1998 had the key breakthrough of “sense and response” as the organizing principle behind his conceptions. As given his nature, Chandy put all his results on his web site, including downloadable software. One day, Caltech’s Office of Technology Transfer called him and suggested he take everything down, as they were getting inquiries from companies who wanted to license the ideas! This phone call led to the germination of iSpheres.

iSpheres faced several challenges. Sense-and-respond systems have to manage large volumes of heterogeneous data ranging from stock ticks at 10,000 per second to news stories and email. These different streams of data have to be

integrated with information in databases and business-intelligence warehouses to detect threats and opportunities such as arbitrage. Then the system must respond appropriately to events, and appropriate response often requires orchestration of services within and outside the organization. The fundamental problem is to build sense-and-respond platforms, layered on top of information technologies such as databases and application servers, which can be configured to deal with different applications. Though the applications are usually complex, the interfaces for configuring the platform are relatively simple: after a few weeks of training, clients can configure the software themselves, for their particular applications.

An exciting part of starting a company, Chandy explained, was talking to users in different industries ranging from energy and stock trading to supply chain management, and solving their concrete problems directly. Creating a product that affects people's lives was exhilarating and demanding because the product is used in mission-critical applications. In the academy, the "metrics for success are fuzzier," the problems solved are removed from concrete requirements in different industries, the pressure to make systems work 24/7 is less intense, and sometimes solutions are appreciated

only by other academics. It was also a revelation to pitch ideas to investors—the process of getting your ideas funded in the venture-capital marketplace was quite different than getting your ideas funded by granting agencies, and more satisfying in many ways.

Chandy learned how industry works, how essential effective leadership is, and that a company is not simply a technology. The *culture* of the company is crucial, and he strove to make iSpheres a nurturing environment for employees, an environment where they could grow and evolve. However, the discipline of the marketplace was the constant and final arbiter of what the company could (or could not) do. This fiscal discipline was brutal, especially concerning hiring and firing, and this was perhaps the most difficult part of starting a company.

**T**he original idea of crisis-management systems that would assist rescue workers and investigators evolved at the company into decision-making systems for financial institutions and manufacturing concerns (the investors realized that the core product had to be revenue generating). So, Chandy is back in his Caltech lab figuring out ways to improve the software for crisis-management applications. He feels that for some (but not all) problem

spaces, giving away systems freely is more effective than building commercial products. He's come full circle, but in the process created and disseminated ideas far and wide. Other application areas he is working on include systems that would assimilate the vast amounts of heterogeneous biological information available to detect significant opportunities, as well as systems that would allow one to study new types of financial markets (see article on Information Science and Technology, page 18). He is eager to become engaged again with the deeper mathematical issues of the work. If he were younger, he hinted that perhaps working in startups periodically, or even on a fulltime basis, would be a tempting direction; but now, with his start-up company out of its infancy and on its way to childhood, he is very satisfied to delve back into the challenging theoretical concerns at Caltech. ■ ■ ■

---

There is more on Professor Chandy at <http://www.infospheres.caltech.edu>

## Orbits of Light: Kerry Vahala and His Miniature Lasing Spheres

**C**onsider a tiny glass sphere or spherical droplet. What would happen if light could be launched at near-grazing incidence along its interior wall? This would yield the optical equivalent of the familiar acoustical whispering gallery.

In optical whispering galleries, solution of Maxwell's equations shows that light can be guided along trajectories that are tightly confined near the surface of the sphere. Because of spherical symmetry, these whispering-gallery solutions (also known as modes) correspond with solutions to the classic hydrogen system of atomic physics. If the sphere is large—compared to the scale of the wavelength of light—we can expect to be able to interpret the whispering-gallery motion as an orbit in the sense of an approximate ray-optics picture.

Light trapped within a glass sphere as a ring orbit is shown on the opposite page. Although the sphere shown here has a diameter less than the thickness of this page, it is nonetheless large on the scale of the wavelength of light, and the mode in this case clearly meets our notion of an orbit. One comment is in order: the “light” that has been trapped in this sphere is actually in the infrared, but has been made vis-

ible by the addition of a tracer element within the sphere that enables up-conversion to the visible green band.

Optical whispering galleries can be made in several geometries.

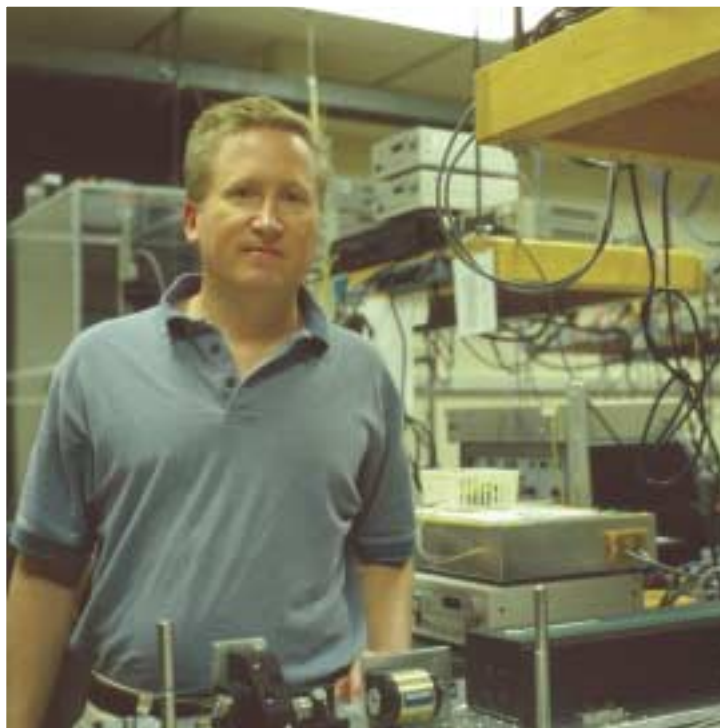

In addition to spheres or droplets, it is possible to fabricate disks, rings, and racetrack geometries using combinations of lithography and etching processes similar to those used in the semiconductor industry.

However, what makes droplets (or spheres formed first as droplets) special is the near atomic perfection of their surface finish. Unlike lithographed or etched whispering galleries, which are considerably rougher, a sphere's shape is determined in the molten state by sur-

face tension. It therefore exhibits a degree of surface perfection very difficult to match by other means. Surface blemishes and roughness tend to randomly scatter light from whispering-gallery orbits and thereby degrade light storage time.

The lifetime of the mode as given by its quality factor, or  $Q$  value, is an easy way to measure the superior performance of spherical micro-cavities in comparison to semiconductor-processed micro-cavities.  $Q$  values for silica microspheres formed as molten droplets can exceed 1 billion, while the record for a lithographically processed structure is nearly 5 orders of magnitude lower. This difference has made droplets and

spheres an object of interest for some time in a number of different fields.

In a ray-optics picture, a  $Q$  value this high means that light inside a sphere about 30 microns in diameter will trace out orbits up to a million times before leaving the cavity. Returning to the acoustic analogy, a true whispering gallery with an equivalent  $Q$  value of 100 million could resonate or “ring” for over an hour.

Introducing or “coupling” light into the high- $Q$  modes of a spheri-



cal whispering gallery is non-trivial. Efficient coupling requires first that the orbiting wave's phase velocity be matched with the input wave, something not possible from free space. Then, through a process called directional coupling, it is possible to excite whispering-gallery orbits using waveguides of similar (but not necessarily identical) cross section and refractive index.

Remarkably, these waveguides can be fashioned from optical fiber filaments in the form of a narrow taper. This is of considerable practical importance. Optical power, initially guided within the interior of a fiber cable, can be converted by the tapers into waves guided along micron-wide filaments, and then back again.

Some time ago the Vahala group demonstrated that such tapers could be prepared in such a way that coupling both to and from orbital modes is exceedingly efficient. This process "links" the spherical whispering-gallery system to the technologically important world of fiber-optic communications.

**A**

number of new devices have demonstrated the capabilities of these systems: for example, a laser

that uses only the glass itself as the lasing medium. To understand how this device functions, note that ultra-high  $Q$  in a tiny package can concentrate optical energy in a tiny volume. Imagine a ring orbit excited by an optical fiber taper. Consider the buildup of power within the ring volume. When the taper and the sphere are coupled appropriately, energy will store with a time constant given by the cavity  $Q$  such that the higher the  $Q$ , the

greater the energy stored. For spheres with diameters in the range of 30–40 microns, optical power circulates within a ring volume of about  $10^{-15}$  meter<sup>3</sup>.

Putting all of this together, a fiber taper providing incident power in the range of 1 milli-watt, coupled to a sphere with  $Q$  of 100 million, will induce an intensity buildup within the ring orbit in excess of 1 giga-watt/cm<sup>2</sup>. At these intensity levels, normal glass—one

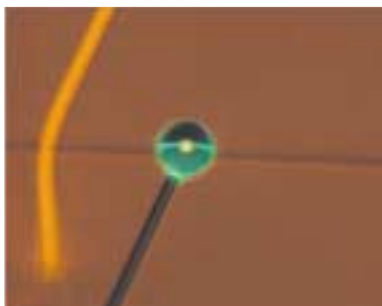



Micrograph showing a 40-micron diameter silica microsphere that is doped with the rare earth erbium. Upon incorporation into silica, erbium ionizes to the 3+ state and exhibits dipole transitions in the green and near infrared. In the micrograph one of these transitions has been excited by optical pumping through a fiber taper. The taper can be seen in the micrograph as the slightly out-of-focus horizontal line. The green ring emission from the sphere corresponds to a fundamental whispering-gallery mode of the sphere. This particular sphere is also lasing in the 1.5 micron band (the important telecom band). The lasing emission is efficiently coupled onto the same fiber taper used for optical pumping.

of the most linear of optical media—exhibits properties out of the range of our normal experience. Optical propagation can no longer be understood using linear optics, as the molecular motion of the glass becomes highly distorted and gives rise to new optical frequencies and behavior.

One manifestation of this transition is *Raman emission*, a process

in which glass actually amplifies certain wavelengths, rather than becoming weakly lossy. With this optical amplification in a cavity, the glass whispering gallery emits new laser frequencies back into the same taper used to couple the "pump" wave. Other startling effects are observed associated with low-frequency phonons of the glass bead, as well as nonlinear mixing.

Vahala's group continues to research properties of this and other whispering-gallery-based devices. The Raman laser described above, in addition to providing a window on nonlinear cavity physics, may be of practical importance as a compact, ultra-efficient wavelength source. Vahala and Applied Physics graduate students Sean Spillance and Tobias Kippenberg reported on this device in *Nature*, February 7, 2002. The device set a record for threshold power (the power necessary to induce laser oscillation) of only 60 micro-watts. With further improvements in  $Q$  underway, it should be possible to lower this value to mere nano-watts.   

*Professor Kerry Vahala (BS '80, MS '81, PhD '85) is the first occupant of the Ted and Ginger Jenkins Professorship in Information Science and Technology. Ted Jenkins (MS '66) and his wife, Ginger, established the professorship in early 2002.*

More on Professor Vahala's work at [http://www.aph.caltech.edu/people/vahala\\_k.html](http://www.aph.caltech.edu/people/vahala_k.html)

**Ivett Leyva:** An Experimentalist with International Flair  
Aeronautics, PhD '99

With this issue we are beginning our practice of offering two alumni profiles—one of a “neophyte” (an alum who has recently graduated), complemented by a second profile of an established Caltech “ex-pat.”

Ivett Leyva graduated from Caltech in 1999 after spending, she declares, “seven great years” in residence, first as an undergraduate (transferring from Whitman College), then as a graduate student working with Professor Hans Hornung. Her PhD was in Aeronautics, her thesis on the shock detachment process on cones in hypervelocity flows.

Upon graduation, she left southern California for upstate New York, joining the General Electric Global Research Center as a mechanical engineer. She has been involved in a wide spectrum of technologies in her first three years at GE, including cycle analysis of microturbines, experimental testing of fuel cells, and currently, design of domestic gas burners and pulse detonation engines (PDEs).

“Working on PDEs is absolutely fascinating,” Leyva explains. “They promise to be a crucial step in the ever-harder fight for higher cycle efficiency for aircraft engines.” In a PDE, energy from the fuel/air mixture is released through a detonation (a supersonic shock wave coupled with a chemi-



cal-reaction zone). “I am involved in the conception of ideas, transformation of ideas to manufacturing drawings—including the minutiae involved with making an idea easily manufacturable—and testing resulting prototypes.” The final step is analyzing results, then presenting and discussing them with program managers and VPs. “I have been very fortunate to travel twice to Russia and work very closely with Russian researchers. I have created joint programs with them, negotiated the scope and schedule of projects, and made sure that the schedule of deliverables was met.” Leyva has had opportunities to

publish and present PDE work at several conferences. And in 2002, she had six patents filed.

Leyva is also involved in design and testing of next-generation domestic gas burners. “I am the liaison between the manufacturing facility in Mexico (where I can practice my native language) and our research facility here. What I like most about this project is my exposure to this very short business cycle, very different from that of aircraft engines. It is also gratifying to see the very fundamental research we do get applied to such familiar products as domestic gas burners.”

“One of the things Caltech best prepared me to do is be a very careful planner of my experiments,” Leyva observes. “From my advisor [Hornung] I also learned the power of back-of-the-envelope calculations and the great value of doing CFD [computational fluid dynamics] and lab experiments hand-in-hand to strengthen and best use the results of both. Professor Paul Dimotakis taught me that a good experimenter really knows all the ins and outs of her experiment, and I try to abide by that philosophy.”

She also fondly remembers her friends on campus, “who made me a very happy student.”

“At GE I have learned to merge analytical and academic knowledge I gained at Caltech with more practical and experience-based knowledge gained through my first few years here. Perhaps the only thing I wish I

had had more experience with while at Caltech is more exposure to the practical considerations of manufacturing, such as making successful and safe aircraft engines. I have had to learn many of these things as I go.”

Leyva feels the years she spent at Caltech “are some of the best in

my life. I’m grateful to the GAL-CIT community who made me feel like a family member. I hope that through my work and citizenship I make them proud.” **E N G**

## Eric Garen: Education at the Fore

Electrical Engineering, BS '68

What are the pivotal experiences that shape a person’s life, that lead him or her down one path rather than another? We spoke to Eric Garen in his Los Angeles home about these experiences, about his Caltech education, about the formation of his company, Learning Tree International, and about his current projects. What emerged is a picture of someone who has successfully applied a rigorous, analytical approach to problem solving, whether it be of complex business problems, or of social problems that plague inner-city youth trying to make their way to college.

We begin in the early 1970s, on the eve of the advent of the personal computer. Intel was manufacturing their early microprocessors (the 4004 and the 8008), and engineers were struggling with how to use these new devices. Eric Garen was one of those engineers.

# A

fter graduating from Caltech in 1968, I went to work at Technology Service Corporation, a small think

tank in Santa Monica that was an offshoot of Rand. After a few years, I began to incorporate minicomputers and then microprocessors in the real-time radar simulators we were designing and building. But learning how to use the early minicomputers and Intel’s first microprocessors was basically a trial-and-error process. You made a lot of mistakes and did things the wrong way. It became clear that that wasn’t the best way to learn. So I joined with fellow engineer and Stanford graduate Dr. David Collins to form a company

that would train other engineers like ourselves on new technology. In 1974 we formed Learning Tree International.

We went into business in Dave’s spare bedroom. We used his garage to store our course materials. We were an upscale start-up—we had a bedroom in addition to the traditional garage! We put 20,000 or so flyers describing our first microprocessor course into the mail and sure enough, people started sending us enrollment forms and checks. Initially I was the course developer and instructor, and Dave was the operations department and marketing department. We packed boxes with our course materials (and a few stray autumn leaves) out in the driveway, and



sent them off to course sites. A month after running our first course in Los Angeles, we were running courses on the East Coast and a month after that, in London and Paris.

**Learning Tree International offered courses on a global basis right from the start, and as a result, half of their business now is in the U.S. and half is outside, primarily in Europe and Canada. They also have offices in Tokyo and Hong Kong.**

Our business concept was to offer courses in new technologies as they were being introduced. Microprocessors formed the first technological wave that propelled our business forward throughout the 1970s. In the 1980s, the networking wave moved us forward, and created needs for training in distributed computing, UNIX, C and data communications. Then in the 1990s, the client-server wave propelled us beyond the engineering departments we were serving and into our customers' information systems groups. And now the Internet wave is pushing us forward again. Today we offer about 150 different courses and have trained over one million IT professionals around the world.

**The impact of his Caltech education on his subsequent endeavors was pervasive, but not in the traditional sense of applying the specifics of his electrical engineering background to his work.**

My Caltech education provided me with good organizational skills and taught me how to learn. You can't get through Caltech without being reasonably organ-

ized, despite the typical Techer's desire in the mid-'60s, mine included, to appear sort of "laid back." I left Caltech with the ability to apply an analytical, quantitative approach to problems and to make data-based decisions. Because both Dave [Collins] and I are analytical, it's not surprising that our company is highly data driven. We have built systems throughout our organization for collecting and analyzing data. Early on, we realized that we had to start "procedurizing" things, "systematizing" things, if we were to grow the company to any size. Most important were the pro-

ing procedures in place that ensure consistent results. And then having a "meta-procedure" for reviewing and improving our procedures on an on-going basis, so that over time the procedures, and the results, get better and better.

It's really exciting to figure out how you take a seemingly amorphous field like teaching advanced technology, and turn it into a logical, coherent, structured process that ensures that results are consistently achieved. Every course participant evaluates our courses and our instructors, and each year our average instructor GPA gets just a



cedures we developed to ensure the quality of our training, because ultimately that's what drives our growth. After taking our courses, our participants return to work and succeed in their projects because they gain the skills they need. So how do we ensure every attendee at every course succeeds when we're running 8,000 courses a year in 30 countries around the world? The only way we can do that is by hav-

little bit higher. Today, it's running just over 3.82. We still have some room before reaching 4.0, but we're edging ever closer.

**In 1956, when Garen's father, a chemical engineer, took a job in the new rocket industry (at Aerojet General), the family relocated from Greenbelt, Maryland to Sacramento, California. A few years later,**

the young Garen found himself attending Folsom High School, just down the road from the Folsom Prison that Johnny Cash made famous. In those years, the education there was rather fundamental...

When I got to Caltech, I experienced a rude awakening because I had no calculus or advanced science classes in high school. Dr. [Rochus] Vogt did a terrific job teaching frosh physics that year using the Feynman books. His first lecture with air troughs just blew my mind. It was exciting, but the pace of the lecture, the course, and my entire freshman year were staggering.

I hadn't made up my mind whether to go into biology or engineering. But in freshman physics we were given a problem and told to solve it by writing a computer program for the largest computer on campus, an IBM 7090—most of us had never seen a computer before, much less used one. They gave us a thin FORTRAN manual and said "Go." So there we were, trying to figure out how to compute the trajectory of a rocket traveling from the earth to the moon, and not getting our program, or our rocket, off the ground. My partner and I had to teach ourselves FORTRAN, making one mistake after another. It was an experience that prepared me for my similar encounter with the Intel 4004 microprocessor a few years later. After first fighting our way through seemingly endless syntax errors, we encountered our first programming mistake—putting data into the first

column of the printout and discovering that a 1 in the first column served as a control character that caused the page to eject. Our printout was about a foot and half high, with one row of data per page! Eventually we got our program working. I learned a lot of FORTRAN in the process, and found myself hooked on computer technology. That experience was pivotal. I declared an EE major—and realized that trial and error is really a terrible way to introduce people to computers.

**M**

y second pivotal experience occurred in my senior year. One of my Dabney House friends,

Charles Zeller [BS '68], had married the year before. His wife attended Pasadena City College and was taking a modern dance class with a young woman named Nancy Graeber. The Zellers introduced us in the fall of 1967, a week later we went to a Grateful Dead concert, and we've been together since. So you can see I came out of Caltech with much more than just an engineering education!

I think that for me, the greatest thing about Caltech is that it's a concentrated environment where you establish lifelong bonds with people who have similar interests and similar analytical capabilities. It's a phenomenal environment and attracts phenomenal people.

My third pivotal Caltech experience was meeting the guys—yes, it was still all guys in those years—who have become my friends for life. In fact, for the past 11 years, seven or eight of us have had a

reunion each year with our families. It's amazing how much satisfaction we get by sharing some wonderful experiences together each year.

In 2000, Garen and his wife established two scholarships at Caltech specifically for students from very low-income families. In the same vein, they have turned their energies recently to two community programs: One Voice and Bright Prospect.

Several years ago, we began to provide support for One Voice, a grass-roots community service organization in Santa Monica, California. One of their programs identifies high-performing high-school juniors from financially disadvantaged living situations—generally inner-city kids who have proven they are capable of succeeding at top-ranked colleges, but who are unlikely to get there without counseling, support, and complete financial aid. These kids come from high-risk environments, but they are not at-risk youths. These are young people who have overcome huge obstacles and done very well in high school through their own talent and determination.

One Voice counsels them, prepares them for their SAT tests, guides them on their college essays, gets recruiters from top universities to interview them, helps them decide on a list of schools, and structures their application process. As a result, every student in the program gets admitted to top schools, and receives full tuition and room-and-board packages from them. One Voice then provides

supplemental funds for airfare, clothing, books, and living expenses.

This whole area has troubled me for a long time: we have in our very affluent society a significant fraction of our population that is economically disenfranchised. And that gap, if anything, seems to be widening. That cannot be a stable situation and we need to do something about it. So this seemed to be a small step in the right direction of helping to create a path out of that environment for kids who at least have the gumption to go that path. When these kids succeed, they inspire more and more kids to follow. And who knows, at some point, it may actually start to steer the direction of the boat differently than it's going now.

The One Voice program has been extraordinarily successful—they have had over 120 students in their program and only one has dropped out. And of the kids who have graduated, close to 40% have gone on to graduate school. They have students doing graduate work at MIT. They have students in medical school at Stanford. They've graduated their first lawyer who passed his bar exam on the first shot.

Nancy and I sat down with the directors from One Voice a few years ago and said, we're helping 20, 25 kids a year. But is it scaleable? Could this be 200 kids or 2,000 kids a year? That encounter led us to incorporate a new non-profit organization located in Pomona [California] called Bright Prospect Scholar Support Program whose mission is to replicate the One Voice program, and then spread it to other communities. Bright Prospect has implemented exactly the processes that One Voice uses, because in business I've learned that when you find a

process that's successful, you need to document it, replicate it, and only slowly make incremental changes to improve it.

Last spring we identified our first group of 12 kids. This past fall, recruiters from 30 top colleges visited Bright Prospect to meet our students, and soon we'll know where these students will be going to college.

O

ther programs that have attempted to help students from similar situations often experience a 50% or greater drop-out rate. This is not because the students don't have the academic or intellectual capability. It's simply a culture shock. They're being plopped down in an environment that's alien and that they don't feel a part of. So the support organization must stay with the students: by e-mail, by telephone, by personal visits, by intervening, by calling up the dean if necessary.

Bright Prospect's goal is to replicate the One Voice program successfully, and to raise sufficient funding to make the program self-sustaining. That will free up our seed capital and allow us to go out and replicate the program in other locations, either by opening more Bright Prospect offices or by finding other community service organizations that want to add this program to their activities. That's the vision. In ten years, we would like to have at least 1,000 students in our program, 200 students at each grade level. That's a modest goal, but one we are determined to achieve. And we hope to make it a lot bigger than that.

**While Garen spoke in detail about the formation of his company and the creation of**

**Bright Prospect, he also touched briefly on family life as our interview drew to a close. He and Nancy have two children, a daughter, Nicole, and a son, Steven. He noted (with a smile) that taking his daughter to college was just not the same as when he went off to Caltech.**

Taking our daughter to college was a whole different experience than I remember from arriving at Caltech. Nicole entered Washington University in St. Louis last August as a double major in pre-med and fine arts. Helping her move in, I felt like a rock band roadie. We practically needed a bus and four semis to get everything to her dorm room... well, I suppose that's a bit of an exaggeration, but Nicole has a little refrigerator. A microwave. Computers, printers... I just showed up in Pasadena with one suitcase and a manual typewriter.

Our son, Steven, is a junior at Harvard Westlake High School and like his sister, he's good at both art and academics. Steven plays guitar in a band—they're quite good and play at the Roxy and the Whiskey on Sunset Boulevard. But they change their name so often I am not sure what they are called this week. Maybe my roadie experience will come in handy again one day when they go on tour.

A terrific wife who I met at Caltech. Great kids. Lifelong Caltech friends. Applying what I learned at Caltech to make a difference in peoples' lives. What more could one hope for from a Caltech education? ■ ■ ■



The mission of the California Institute of Technology is to expand human knowledge and benefit society through research integrated with education. We investigate the most challenging, fundamental problems in science and technology in a singularly collegial, interdisciplinary atmosphere, while educating outstanding students to become creative members of society.

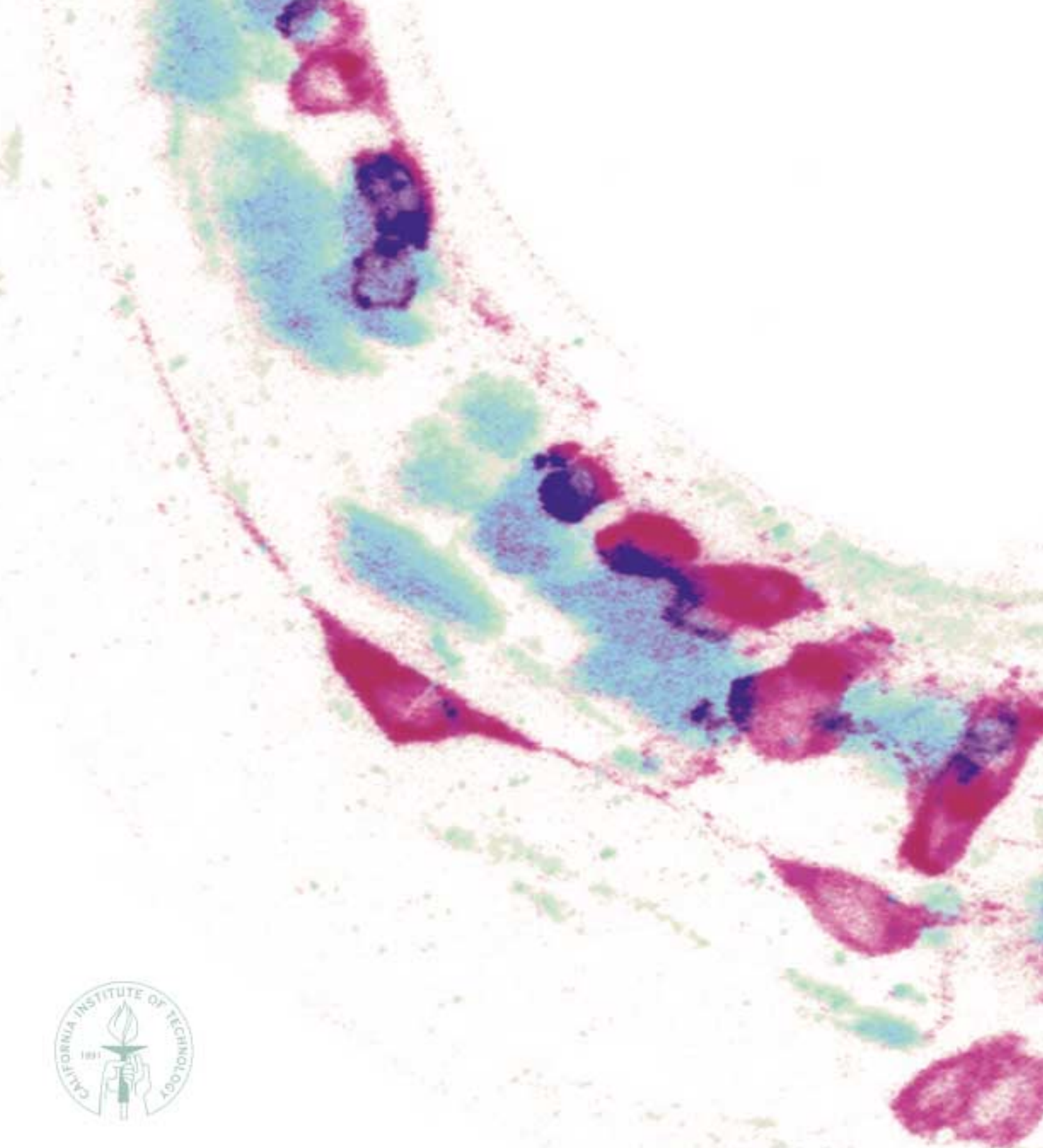

division of engineering and applied science

*California Institute of Technology* 1200 E. California Boulevard, Mail Code 104-44, Pasadena, CA 91125

[www.eas.caltech.edu](http://www.eas.caltech.edu)